

UTILITY EXCAVATION CRITERIA MANUAL
GENERAL REQUIREMENTS AND PROCEDURES
FOR
EXCAVATION IN CITY OF LIVE OAK
PUBLIC RIGHTS-OF-WAY



**CITY OF LIVE OAK PUBLIC
WORKS DEPARTMENT**

September 30, 2016



CITY OF LIVE OAK

8001 Shin Oak Dr.
LIVE OAK, TEXAS 78233

NOTICE TO ALL EXCAVATORS AND USERS OF THE PUBLIC RIGHT-OF-WAY IN CITY OF LIVE OAK

The Utility Excavation Criteria Manual (UECM) has been prepared as a guide for City agencies, utility companies, contractors, right-of-way users and others excavating in the public right-of-way of Live Oak, Texas.

The main purpose of the Manual is to collect the various specifications, rules and regulations governing excavations in the public right-of-way into a single document. The user of the Manual is responsible for ensuring that all documents contained therein are kept up to date. To assist the users the City will notify all users on record of changes made to the Manual.

The main focus of the regulations is to:

- Protect the traveling public;
- Protect the City Infrastructure investment;
- Improve coordination of construction within the right-of-Way;
- Minimize the impact of construction in the public right-of-way and;
- Recover cost of damage done to infrastructure by construction.

Before excavating in any public right-of-way within the City limits, excavators are encouraged to familiarize themselves with the requirements of this manual.

DIRECTOR OF PUBLIC WORKS

INTRODUCTION

Inevitably, much of a utility's facilities are buried beneath street pavement or other paved areas in Public Right-of-Way. Thus, in order to access existing facilities, install new pipelines, appurtenances, etc. there is a need to cut the street pavement structure. "Entities making and benefiting from an Excavation in a City street also should comply with standards and requirements for compaction, backfill and pavement restoration and resurfacing that ensures the best possible restoration of the paved surface over and adjacent to the trench", *Right-of-Way Ordinance No.* _____

In recent years, coordination between agencies and utilities has improved so that the bulk of utility work is scheduled to occur prior to pavement construction, rehabilitation or resurfacing activities, thus avoiding (to the maximum practical extent) the cutting of new pavements. However, unscheduled cuts cannot be entirely eliminated. Leaks must be repaired; new customers wanting service must be connected up on demand, and so forth. Thus there will always be utility cuts in both new and old pavements.

The crucial issue after the utility has performed the work that necessitated the cut in the first place, is to restore the pavement to a satisfactory structural and rideability standard. This encompasses the need to match the structural parameters and performance of the surrounding pavement, and the need for good workmanship to provide a riding surface that merges smoothly with the surroundings and avoids sudden changes of elevation or slope. The structural and rideability needs are separate but intertwined.

The City of Live Oak is concerned and charged with the maintenance of a fundamental infrastructure component that provides modal carriage for safe transportation, quality of life, etc. As the City continues to expend funds for the maintenance of streets, investment preservation and sustention must be exercised. Proper barricading providing advance warning and work zone precautionary notice is significant in the City's effort in providing a safe intermodal environment. This manual includes guidelines for work methods and related safety procedures to follow and materials to be used by those involved in utility work within the City of Live Oak's Right-of-Way.

TABLE OF CONTENTS

CHAPTER	DESCRIPTION	PAGE
1	GENERAL REQUIREMENTS	6
1.1.0	CHAPTER INCLUDES	7
1.2.0	REFERENCES	7
1.3.0	DEFINITIONS	7
1.4.0	QUALITY ASSURANCE	8
1.5.0	DESIGN REQUIREMENT	8
2	COORDINATION OF UTILITIES	11
2.1.0	GENERAL	12
2.2.0	COORDINATION PROCESS FOR CAPITAL PROJECTS	12
2.3.0	SCHEDULED WORK (SHORT TERM)	13
2.4.0	EMERGENCY EXCAVATION	13
3	UTILITY ASSIGNMENT IN RIGHT-OF-WAY	14
3.1.0	GENERAL	15
3.2.0	UTILITY LOCATIONS	15
4	UTILITY EXCAVATION IN PUBLIC RIGHT-OF-WAY	21
4.1.0	GENERAL	22
4.2.0	PERMIT FOR EXCAVATION IN PUBLIC RIGHT-OF-WAY	23
4.3.0	OTHER APPLICABLE COSTS	25
4.4.0	EXCAVATION, JACKING AND BORING IN PUBLIC RIGHT-OF-WAY	25
4.5.0	BACKFILL OF EXCAVATED AREA	30
4.6.0	RESTORATION OF EXCAVATED AREA	36
4.7.0	PAVEMENT REPAIRS	40
4.8.0	MATERIAL SPECIFICATIONS	44
4.9.0	MISCELLANEOUS REPAIRS	47
4.10.0	TRAFFIC CONTROL PLANS FOR CBD AND MEDICAL CENTER	50
4.11.0	TESTING	50
5	STREET PAVING DESIGN REQUIREMENTS	52
5.1.0	CHAPTER INCLUDES	53
5.2.0	REFERENCES	53
5.3.0	DEFINITIONS	53
5.4.0	DESIGN REQUIREMENTS	53
5.5.0	QUALITY ASSURANCE	56
5.6.0	DESIGN ANALYSIS	56
5.7.0	STANDARD PAVING NOTES FOR DRAWING CALL OUTS	57
6	SURVEY REQUIREMENTS	64
6.1.0	CHAPTER INCLUDES	65
6.2.0	REFERENCES	65
6.3.0	DEFINITIONS	65
6.4.0	SUBMITTALS	65
6.5.0	QUALITY ASSURANCE	65
6.6.0	FIELD WORK	65
6.7.0	CALCULATIONS	66
6.8.0	CONSTRUCTION DRAWINGS	66
6.9.0	RIGHTS-OF-WAY	67
6.10.0	DOCUMENTS	68
7	GEOTECHNICAL REQUIREMENTS	69
7.1.0	INTRODUCTION	70

7.3.0	INVESTIGATION REQUIREMENTS	70
7.4.0	INVESTIGATION OF GRANULAR AND COHESIVE SOILS	71
7.5.0	INVESTIGATION CRITERIA	71
7.6.0	LABORATORY TESTING PROGRAM	72
7.7.0	SURVEY REQUIREMENTS	73
7.8.0	SITE RESTORATION	73
7.9.0	GEOTECHNICAL REPORT	73
8	STANDARD DRAWINGS	74

Chapter 1

GENERAL REQUIREMENTS

GENERAL REQUIREMENTS

1.1.0 CHAPTER INCLUDES

Research submittal requirements for projects within the right-of-way inside the city limits of Live Oak, Texas.

1.2.0 REFERENCES

The following references should be reviewed in conjunction with this manual:

- A. Chapter 20, City code of the City of Live Oak
- B. Unified Development Code of the City of Live Oak
- C. City of San Antonio Standard Specifications for Public Works Construction (# edition).
- D. Texas Accessibility Standards (TAS) of the Architectural Barriers Act, Article 9102, Texas Civil Statutes.
- E. Rules and Regulations published by Texas Commission on Environmental Quality (TCEQ).
 - 1. TCEQ Chapter 290: Public Drinking Water, latest revisions.
 - 2. TCEQ, Chapter 217: Design Criteria for Domestic Wastewater Systems, latest revisions.
- F. State of Texas Engineering Practice Act.
- G. State of Texas Professional Land Surveying Practices Act.
- H. Storm Water Management Handbook for Construction Activities, Latest Edition as Prepared by City of Live Oak.
- I. Live Oak Water System Rules & Regulations and Standard Specifications for Construction.
- J. Texas Department of Transportation Standard Specifications for Construction and Maintenance of Highways, Streets and Bridges
- K. Texas Manual on Uniform Traffic Control Devices (TMUTCD)

1.3.0 DEFINITIONS

- A. **DIRECTOR** – The City of Live Oak Director of Public Works, or his designee, having approval authority for privately- funded projects, or having authority for administration of design and construction contracts for the City of Live Oak.
- B. **REVIEW AUTHORITIES** – The authorized representative of the Public Works department, divisions, or sections responsible for reviewing and approving calculations and drawings for publicly and privately funded projects and for design and construction contracts with the City of Live Oak.
- C. **DRAWINGS** – Plan, profile, detail and other graphic sheets to be used in construction contract which define character and scope of the project.
- D. **DESIGN ANALYSIS** – Narratives and calculations necessary to support design of a project.
- E. **PROFESSIONAL ENGINEER** – An engineer currently licensed and in good standing with the Texas Board of Professional Engineers.
- F. **PROFESSIONAL LAND SURVEYOR**-A Surveyor currently registered and in good standing with Texas Board of Professional Land Surveying.
- G. **SPECIFICATIONS** – City of San Antonio Standard Specifications for Public Works construction projects, plus project-specifications narrative descriptions of procedures, requirements, and materials for a particular project.

1.4.0 QUALITY ASSURANCE

- A. Research existing utility and right-of-way information with the City departments listed below. Present and discuss the concept of the project with these same departments.
 - 1. Department of Public Works
 - a. Street Maintenance Division
 - b. Utility Operations Division
 - c. Storm Water Division
 - 2. Development Services Department
 - 4. Parks and Recreation Department

- B. Research existing utilities and right-of-way or easements for conflicts. The following represents a listing of known public and private organizations and other active utility company(ies). It is the responsibility of the ROW User to identify all affected entities to avoid conflicts
 - 1. **Texas Department of Transportation**
 - 2. **Telecommunication Companies including but not limited to:**
 - a) AT&T Southwest
 - b) Grande Communications
 - 3. **Cable Television and data companies**
 - a) Spectrum
 - b) Grande Communications
 - c) AT&T
 - 4. **Utility companies:**
 - a) San Antonio Water System (SAWS)
 - b) City Public Service (CPS) Energy
 - c) City of Live Oak Utilities
 - d) City of Selma Utilities
 - e) City of Universal City Utilities
 - f) Private utilities/franchise
 - 5. **Other agencies**
 - a) Union Pacific and other Railroad companies
 - b) Pipeline companies
 - c) Independent School Districts
 - d) Bexar County
 - e) San Antonio River Authority (SARA)

- C. Verify that no restrictions or conflicts exist that will prevent approval and permitting of the project

1.5.0 DESIGN REQUIREMENTS

- A. Preliminary Design.
 - 1. Privately Funded Projects:
 - a. Prior to preliminary design submittal, City reviews are available to discuss alternate solutions for project elements when alternate designs may be considered.

- b. Provide the Director with drawings in sufficient detail to describe the proposed improvements. Include proposed materials, if different from materials approved by the City. Identify any problems or conflicts associated with the project. Information furnished must be sufficient details for the Director to assess whether the design meets current City design standards.
 - c. Provide rights-of-way and easement requirements for the project.
 2. Design Contracts with the City.
 - a. Participate in preliminary conferences with the Director outlining the scope of work and extent of the preliminary report.
 - b. Prepare preliminary engineering studies and designs based upon the scope of work and as outlined in the professional engineering services contract with the City.
 - c. Prepare the contractually specified number of copies of preliminary layouts, sketches, reports and calculations supporting the preliminary layouts. Prepare alternative solutions, where applicable to the project, and include the engineer's specific recommendations.
 - d. Prepare preliminary cost estimates for primary and alternate solutions of the proposed construction.
 - e. Participate in conferences with the City to determine final design.
 - f. When required by the professional services contract, provide detailed soils and geotechnical investigations to support proposed construction of utilities and paving.
 - g. Provide required real estate, rights-of-way, and easement requirements for the project.
 - B. Final Design.
 1. Privately-funded Projects:
 - a. Revise design to reflect comments of the Director and review authorities. Include design calculations to support proposed improvements.
 - b. Provide review prints to the Director and review authorities for verification and compliance with prior review comments.
 - c. Obtain required signatures from governmental agencies (other than the City of Live Oak) and private utility companies prior to requesting signature by the City.
 - d. Include the following note on construction drawings, "Contractor shall notify the City of Live Oak, Department of Public Works Right-of-Way Management Office at (210) 653-9140 Forty-eight (48) hours before this project."
 2. Design Contract with the City:
 - a. Furnish the City, where applicable, engineering data necessary for applications for routine permits required by local, state and federal authorities.
 - b. Prepare detailed final design drawings and specifications in compliance with comments received from the City subsequent to the review of the preliminary design.
 - c. Prepare detailed cost estimates & proposed forms for the authorized project.
 - C. Original Documents
 1. Approved drawings will be assigned a City Project number and must be filed in the City Works Office prior to issuance of a right-of-way use permit. Tracings will become property of the City of Live Oak and will remain on file in the office for

use only by City Staff who may be interested in the project.

END OF CHAPTER

Chapter 2

COORDINATION OF UTILITIES

COORDINATION OF UTILITIES

2.1.0 GENERAL

To provide coordination among all users of the public right-of-way, a coordination process is established to review projects that require construction within the right-of-way. The objective of the process is to identify and resolve any potential conflicts before construction begins.

2.1.1 CHAPTER INCLUDES

The various phases of coordination described with the respective responsibilities.

2.2.0 COORDINATION PROCESS FOR CAPITAL IMPROVEMENT PROJECTS

The project Design Engineer works directly with the Director to obtain information of existing facilities located in the public right-of-way and within the project limits. The Project Designer shall submit five (5) copies of the Drawings and Specifications, a description of the project, project contact, phone and fax numbers to the Director, who distributes the Drawings, Specifications and information of the various utilities and entities having vested interest in the project. The Director shall schedule a review meeting within three weeks after the plans are distributed.

Utility Owners shall submit written comments and a copy of facility maps and plans if available for the project limits. Every effort shall be made to incorporate the comments and information provided by the Utility Owners into the project design.

All adjusted and new facilities will have a minimum cover of 30 inches or in the case of rock/limestone formations a minimum depth assigned to the Utility Owner by the City that assures an appropriate cover depth of the utility below the subgrade. The Excavator or right-of-way user shall insure that the depth assignment is based on a subgrade level that extends below any existing severely weathered rock/limestone layer (i.e. layers composed of fissured rock limestone inter-bedded with clay, silt, sand, etc.).

The Project Design Engineer will be responsible for arrangements to have the project staked and provide final cuts as needed to the utilities. The Project Design Engineer will provide control points. Utility Owners will be expected to adjust one time for each project unless the Utility Owners relocate or install facilities that are in conflict with the current design. If the design of the project changes after the Utility Owners have cleared a project, the cost of second relocation will be borne by the City. Utility Owners, who relocate facilities before final plans are completed or without formal notice, do so at their own risk.

If the design is altered, or the project is delayed for an extended period, it may be necessary that additional reviews be made to ensure clearance by all utilities.

2.2.1 PRE-BID

Pre-bid meetings will be scheduled with members of the Project Design Engineer, the Director, Utility Coordinators of respective utilities and interested contractors who will bid on the proposed project. A Question and Answer period will be held to allow the contractors to discuss the various options of the job and status of utility adjustments.

2.2.2 PRE-CONSTRUCTION

Utility Owners shall attend the pre-construction meeting to provide status information of facilities relocation work. It is strongly recommended that Utility Coordinators attend all Pre-Construction meetings for projects involving their facilities.

2.3.0 SCHEDULED WORK (SHORT TERM)

All Right-of-Way users must advise the Director of their work to be done. All agencies and utility owners engaged in work within public right-of-way must distribute information regarding projects.

2.4.0 EMERGENCY EXCAVATION

All emergency excavations must be reported immediately to the Right-of-Way Management Section of Public Works, (210)653-9140, Monday through Friday, 7:45 a.m. to 4:30 p.m., all other hours, day or night should be reported to the Live Oak Police Dispatch (210) 653-0033. Pavement repairs made to emergency excavations will be considered temporary and must be inspected and restored in accordance with Chapter 4 of this manual. Utility owner must apply and submit an emergency right-of-way use permit within 24 hours of the following working day. Excavation authorized by this section shall be subject to all fees and requirements in accordance with Chapter 20 of the City Code.

END OF CHAPTER

Chapter 3

**UTILITY ASSIGNMENT
IN
RIGHT-OF-WAY**

UTILITY ASSIGNMENT IN RIGHT-OF-WAY

3.1.0 GENERAL

If the utility agency selects to place their utility line(s) within a public right-of-way, the utility line(s) shall be installed in accordance with the following requirements:

- (A) The locations of utilities in any new development or in replacement of the existing utilities in a developed area shall be in accordance of standard drawing 3.4.1 through 3.4.6.
- (B) The replacement of existing utility lines within a public right-of-way in a developed area may not be in accordance with section 3.1.0 (A) if the length of the replacement is less than two city blocks but not more than 1500 feet.
- (C) If the length of the replacement is more than two city blocks or more than 1500 feet, the utility replacement shall be in accordance with standard drawing 3.4.1 through 3.4.6, unless the assigned location is occupied by another utility which will not be replaced. The utility line can be replaced at a location selected by the utility agency. This will not require a variance.
- (D) The utility agencies shall be responsible to coordinate their work within a right-of-way with all other utility agencies.
- (E) When requested, utility agencies are required to provide maps of new utility locations to the Public Works Department.
- (F) Minor variations to both vertical and horizontal alignment that are required to avoid conflict with storm sewer inlet, sanitary sewer manhole, street light pole, traffic signal pole, etc. will be granted and do not require a variance.
- (G) When a sanitary sewer and/or water line is placed under pavement, an adequate number of stub-outs must be provided for future connection(s) in order to avoid cutting the pavement. Stub-outs for sewer and water should be provided for each lot. However, if the main is under rehabilitation and a stub-out is not found, a service and/or a lateral shall be installed.

3.2.0 UTILITY LOCATIONS

3.2.1 Horizontal Location: All utilities shall be installed horizontally as shown on the standard drawing 3.4.1 through 3.4.6, unless approved otherwise.

3.2.2 Vertical Location: The depths of utilities shown on the standard drawing are the minimum cover and must be provided. All utilities shall be installed in accordance with the regulatory agency's requirements.

3.2.3 Clearance from Other Utilities: Any utility crossing another utility line shall maintain a minimum of 12 inches clearance unless explicitly mandated otherwise by regulatory agencies such as TCEQ, EPA, etc.

3.2.4 Fire Hydrant Location: Fire hydrants shall not be located within sidewalks and/or wheelchair ramps. Fire hydrants shall not be located less than two feet (2') from the back of the curb or the projected future curb.

3.2.5 Street Crossings: All utility crossings on any street shall be installed by boring and jacking unless approved by the Director of Public Works. Appropriate encasement and grouting must be used, as approved by a Professional Engineer. Pothole locates will not be allowed in such streets.

3.2.6 Drainage Ditch And Stream Crossing:

- (A) Crossing under a stream or ditch is preferred by the City. The top of the carrier pipe shall be designed to provide a minimum clearance of at least four feet (4') below the ultimate flow line and sides of the ditch and with sufficient bottom length to exceed the ultimate future ditch sections. If the carrier pipe is concrete-encased,

the top of the encasement shall be a minimum of one foot (1') below the ultimate flow line of the channel. When crossing a concrete drainage structure, boring with a minimum of four feet (4') clearance is the preferred method of construction and installation.

- (B) All areas disturbed as a direct effect of construction and installation shall be restored to original or better conditions and replace all disturbed vegetative cover in earthen areas.
- (C) Where existing or proposed bridges have sufficient space and structural capacity for installing water mains or conduits (twelve inches or smaller) under the bridge, but above the top of the bent cap elevation, such installation will be permitted upon specific approval of the construction plans. In all cases the water main or conduit shall be above the bottom chord of the bridge and 18 inches above the 100-year flood water surface elevation. In addition, all utilities shall be located on the downstream side of the bridge or directly under the bridge deck, in order to shield the utility from debris in the event of a 100-year storm. All conduits attached to a bridge shall be constructed using steel pipe and shall extend a minimum of ten feet (10') beyond the bridge bent or to the right-of-way line, whichever is greater. A seal of approval from the City Engineer will be required. All conduit attached to a bridge shall be maintained by the owner of the conduit or will be subject to removal. Bridge attachment is the least desirable condition.
- (D) Separate, free-standing crossings across drainage ways are not allowed.
- (E) All stream or ditch crossings shall be constructed of steel pipe or concrete encased PVC, Ductile Iron and/or HDPE pipe from right-of-way to right-of-way. If the utility crossing is bored and the top of the carrier pipe is less than four feet (4') below the ultimate flow line of the channel, steel pipe or concrete-encased PVC shall be used.

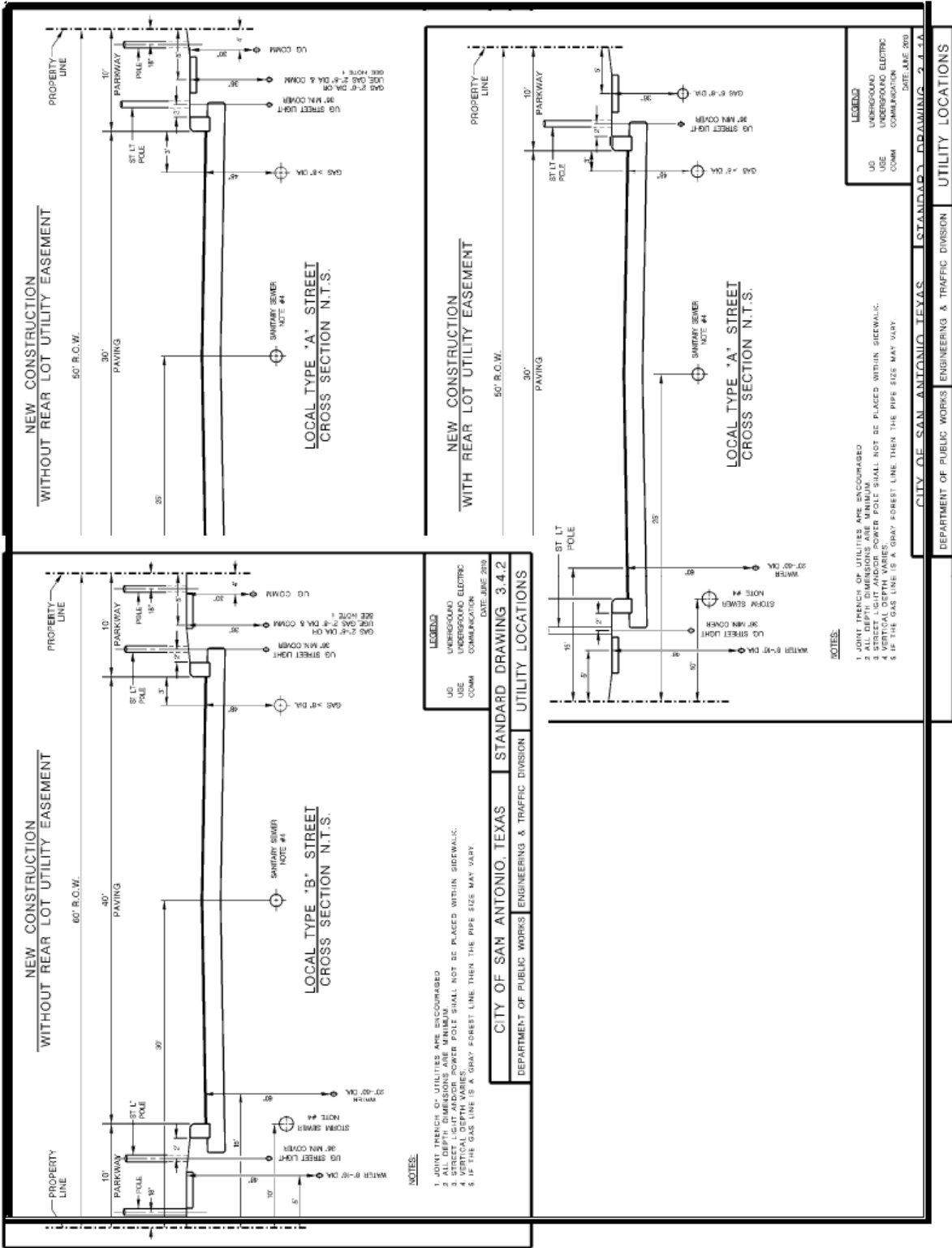

CITY OF SAN ANTONIO, TEXAS
 STANDARD DRAWING 3.4.2
 DEPARTMENT OF PUBLIC WORKS ENGINEERING & TRAFFIC DIVISION
 UTILITY LOCATIONS

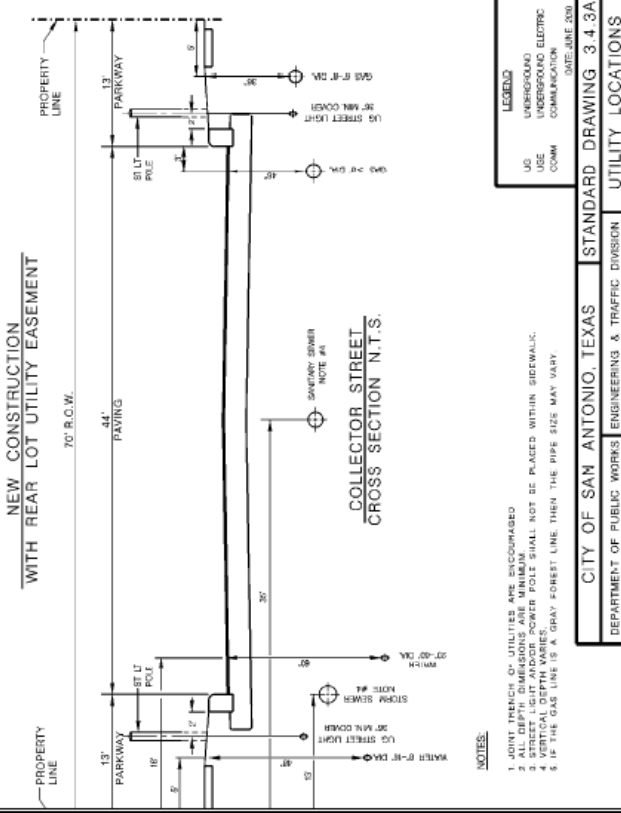
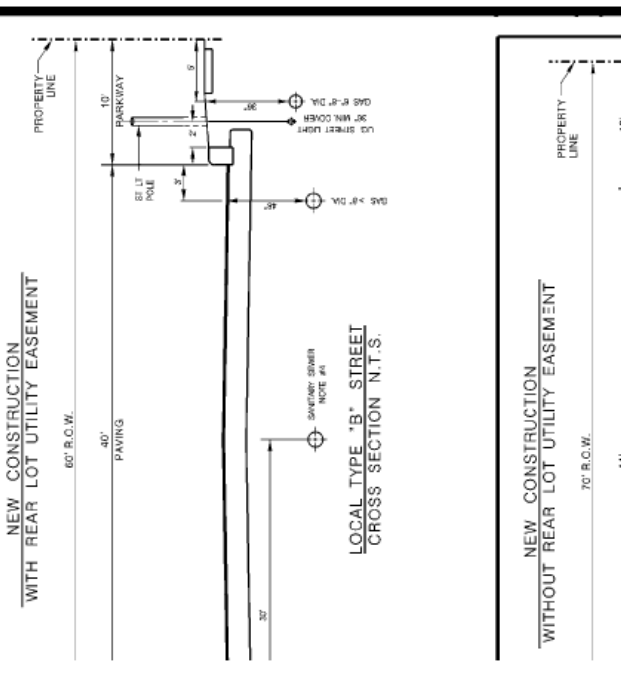

NOTES:

1. JOINT TRENCH OF UTILITIES ARE ENCOURAGED
2. ALL DEPTH DIMENSIONS ARE MINIMUM
3. ALL DEPTH DIMENSIONS ARE MINIMUM
4. ALL DEPTH DIMENSIONS ARE MINIMUM
5. IF THE GAS LINE IS A GRAY FOREST LINE THEN THE PIPE SIZE MAY VARY.

LEGEND

US UNDERGROUND
USE UNDERGROUND ELECTRIC
COMM UNDERGROUND ELECTRIC COMMUNICATION

CITY OF SAN ANTONIO, TEXAS
DEPARTMENT OF PUBLIC WORKS ENGINEERING & TRAFFIC DIVISION
STANDARD DRAWING 3.4.3A
DATE: JUNE 200

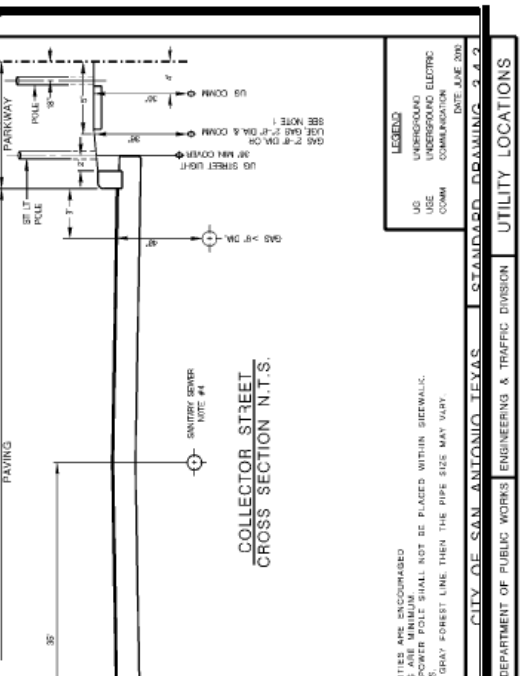

NOTES:

1. JOINT TRENCH OF UTILITIES ARE ENCOURAGED
2. ALL DEPTH DIMENSIONS ARE MINIMUM
3. ALL DEPTH DIMENSIONS ARE MINIMUM
4. ALL DEPTH DIMENSIONS ARE MINIMUM
5. IF THE GAS LINE IS A GRAY FOREST LINE THEN THE PIPE SIZE MAY VARY.

LEGEND

US UNDERGROUND
USE UNDERGROUND ELECTRIC
COMM UNDERGROUND ELECTRIC COMMUNICATION

CITY OF SAN ANTONIO, TEXAS
DEPARTMENT OF PUBLIC WORKS ENGINEERING & TRAFFIC DIVISION
STANDARD DRAWING 3.4.2
DATE: JUNE 200

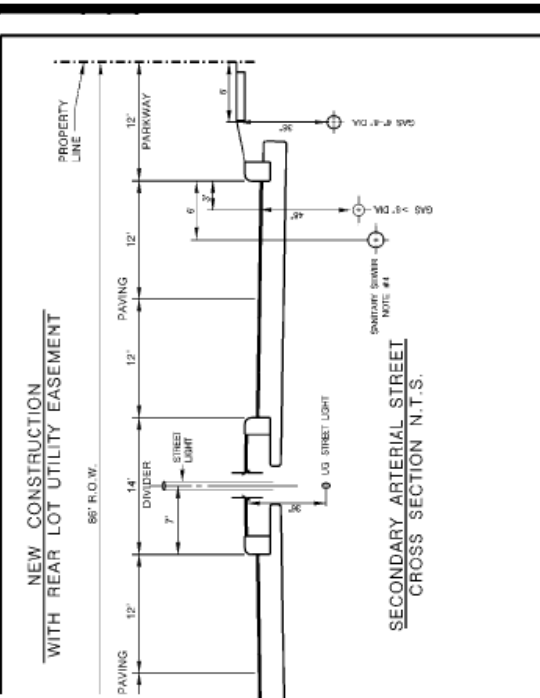
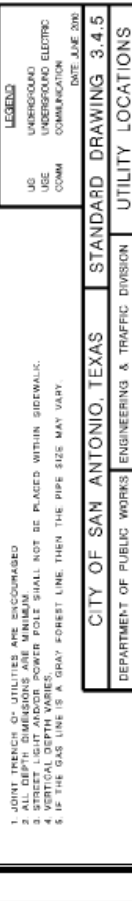
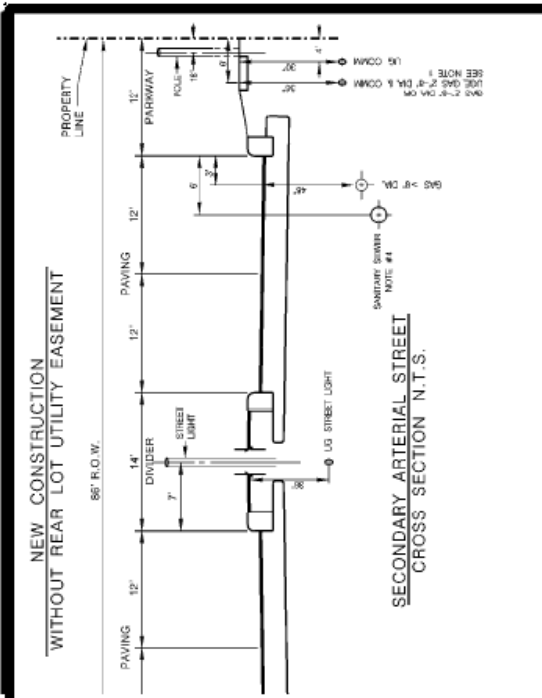
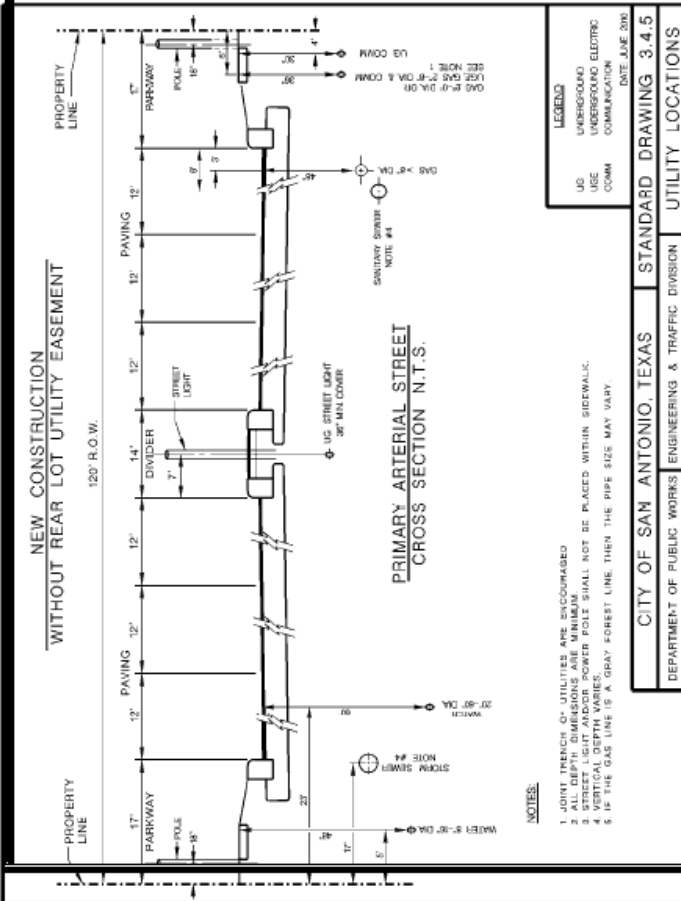

LEGEND
 UG UNDERGROUND
 USE UNDERGROUND ELECTRIC
 COMM UNDERGROUND COMMUNICATION

NOTES:
 1 JOINT TRENCH OF UTILITIES ARE ENCOURAGED
 2 STREET LIGHT AND/OR POWER POLE SHALL NOT BE PLACED WITHIN SIDEWALK.
 3 STREET LIGHT AND/OR POWER POLE SHALL NOT BE PLACED WITHIN SIDEWALK.
 4 VERTICAL DEPTH VARIES.
 5 IF THE GAS LINE IS A GRAY FOREST LINE THEN THE PIPE SIZE MAY VARY.

LEGEND
 UG UNDERGROUND
 USE UNDERGROUND ELECTRIC
 COMM UNDERGROUND COMMUNICATION

NOTES:
 1 JOINT TRENCH OF UTILITIES ARE ENCOURAGED
 2 STREET LIGHT AND/OR POWER POLE SHALL NOT BE PLACED WITHIN SIDEWALK.
 3 STREET LIGHT AND/OR POWER POLE SHALL NOT BE PLACED WITHIN SIDEWALK.
 4 VERTICAL DEPTH VARIES.
 5 IF THE GAS LINE IS A GRAY FOREST LINE THEN THE PIPE SIZE MAY VARY.

CITY OF SAN ANTONIO, TEXAS
 DEPARTMENT OF PUBLIC WORKS
 ENGINEERING & TRAFFIC DIVISION
 STANDARD DRAWING 3.4.5
 UTILITY LOCATIONS
 DATE: JUNE 2006

CITY OF SAN ANTONIO, TEXAS
 DEPARTMENT OF PUBLIC WORKS
 ENGINEERING & TRAFFIC DIVISION
 STANDARD DRAWING 3.4.5
 UTILITY LOCATIONS
 DATE: JUNE 2006

**NEW CONSTRUCTION
WITH REAR LOT UTILITY EASEMENT**

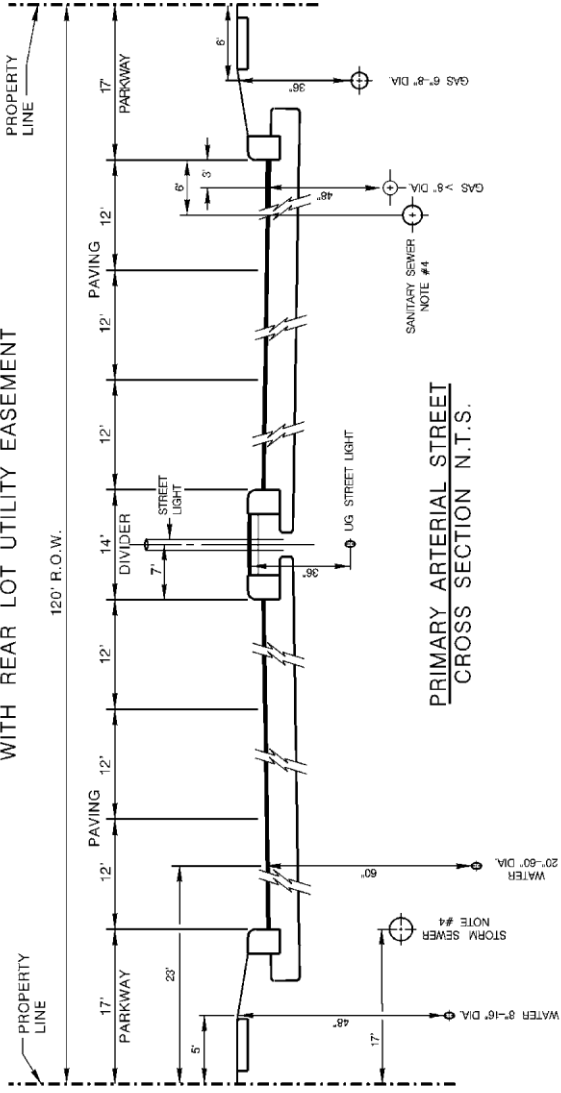

END OF CHAPTER

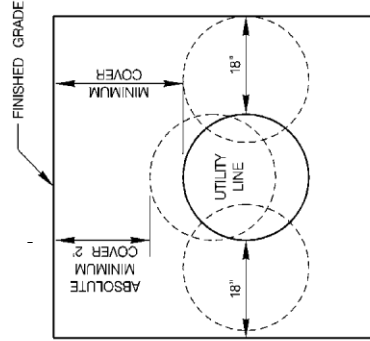

**TRENCH ENVELOPE
N.T.S.**

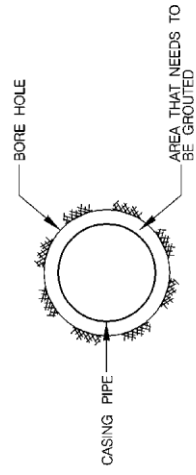

**BORE DETAIL
N.T.S.**

1. THE HORIZONTAL AND VERTICAL LOCATION OF ANY LINE AS SHOWN ON THE STANDARD DRAWING 3.4.1 THROUGH 3.4.5A, MAY VARY AS ALLOWED UNDER TRENCH ENVELOPE, STANDARD DRAWING 3.4.6 AS LONG AS THERE IS NO CONFLICT WITH AN OTHER UTILITY LINE.

Chapter 4

**UTILITY EXCAVATION
IN OR USE OF RIGHT-
OF-WAY**

UTILITY EXCAVATION IN RIGHT-OF-WAY

4.1.0 GENERAL

This section governs excavation practices in the public right-of-way within the city that is under the jurisdiction and control of the Department of Public Works or successor department (hereafter referred to as the Department). This section outlines the procedures for obtaining permits for use of, excavation, performing excavation, and restoration of the public right-of-way.

The office issuing the right-of-way use permit and performing the inspections is the Right-of-Way Management Division of the Department of Public Works for the City of Live Oak.

Detailed descriptions of the policy, procedures, specifications and standard details are included as part of the section or referenced in this section. These guidelines serve as a minimum standard for working in the public right-of-ways.

The following objectives must be adhered to as part of the requirements for working in the public right-of-way:

1. Ensure protection to the public and the work force.
2. Maintain the integrity of the facility already in place and other adjacent facilities.
3. Provide the ability to meet unusual emergency requirements when necessary in construction of the project.
4. Minimize the inconvenience to vehicular and pedestrian traffic as well as to the adjacent landowners.
5. Minimize the variations from the standard of utility assignments.
6. Minimize future maintenance costs to the City caused by the excavation.
7. Minimize time of street closure and interruption of the normal flow of traffic.

4.1.1 REFERENCES

- A. Refer to the list of references in Chapter 1, General Requirements.
- B. Texas Engineering Practices Act & Board Rules and Practices Procedure, latest revision.
- C. AASHTO – American Association of State Highway and Transportation Officials.
- D. ASTM – American Society for Testing and Materials.

4.1.2 DEFINITIONS

The following definitions apply in this chapter of the UECM. The terms, phrases, words, abbreviations, and their derivations shall have the same meanings herein. When not inconsistent with the context, words used in the present tense include the future; words in the plural number include the singular number, and words in the singular include the plural. The word “shall” is always mandatory and not merely permissive.

- A. **BACKFILL** means excavation fill material that meets city specified quality requirements or the placement thereof.
- B. **CIP** means Capital Improvement Projects, specifically new street or drainage construction by the Street Maintenance Program or CIMS Department by the City of Live Oak.
- C. **HOLE** means excavation in the public Right-of-Way with the excavation having a length less than the width of the pavement.
- D. **TRENCH** means an excavation in the pavement with the excavation having a length equal to or greater than the width of the pavement.
- E. **UNDERMINING** means to weaken something by removing or wearing away material from its base or from beneath it; to tunnel or dig beneath.
- F. **ALL-WEATHER MATERIAL** is defined as material that is usable in or able to stand up to all types of weather.

4.1.3 OFFICE LOCATION AND WORKING HOURS

PERMIT OFFICE LOCATION:

City of Live Oak
Public Works Department
Right-of-Way Management Division
8001 Shin Oak Dr.
Live Oak, TX 78233
Monday through Friday- 8:00 AM - 4:30 PM
Office (210) 653-9140 FAX (210) 599-3753
After hours, weekends and Holidays
Office (210) 653-0033

4.1.4 REGISTRATION

All right-of-way users must be registered with the Public Works Department. Registration shall be successfully performed on a one-time basis, prior to commencement of any work. Insurance, Performance/Assurance Bond and Sureties must be approved and on file with the City Secretary's Office, Public Works Department and Finance Department upon registration. A certification shall be provided to each applicant that successfully completes the registration process. Annual registration updates shall be performed on the anniversary of the initial registration certification.

4.1.5 SCHEDULING

Permittee shall call for inspection one hour prior to initiation of final backfill for a trench inspection if classified as a permitted project receiving inspection. Work will be deemed unacceptable and/or temporary if completed without inspection and within one hour of a call for inspection. Permit holder may commence backfill operations one hour after notifying ROW dispatcher.

The Permit Holder shall make arrangements 48 hours in advanced for inspections that are necessary "after working hours" and/or Saturdays, Sundays and holidays. Refer to Chapter 29, Section 29-168 (B).

After all final backfill has been completed and approved; Permit Holder may call for a flatwork inspection if one is required. No flatwork inspection will be performed without an approved backfill control number.

4.2.0 PERMIT FOR EXCAVATION IN THE PUBLIC RIGHT-OF-WAY

Before excavating or use of a right-of-way a person or that person's agent shall obtain a permit under this division, except emergency operations. The expiration date shall be included in the permit. Except as provided by Chapter 20 of the City Code, the permit term must comply with the time period required by the Utility Excavation Criteria Manual for excavation, blocking, or closing, or using the right-of-way. The Director may issue an extension of the permit, upon request. Permits shall be issued for CONTIGUOUS projects not to exceed the following spatial limits:

- A. One Street segment (block) in length or less;
- B. Point Source exploratory excavations (Pot-holes) shall be permitted per block;
- C. Non-Contiguous areas of work shall be permitted individually. This provision includes excavation and traffic control efforts (Street lane, Sidewalk and driveway closures with or without excavation involved), excavation in the parkway (including

but not limited to non-conformance of alignment of power poles as outlined in Chapter 3, bore-pits and pot-holes), paved alleys and drainage right-of-ways.

4.2.1 EMERGENCY WORK

Person excavating must comply with the procedures prescribed in Chapter 20 of the City Code and in this Manual in performing an emergency operation.

4.2.2 PROCEDURE FOR REQUESTING A RIGHT-OF-WAY USE PERMIT

The applicant may submit a request for a permit in person at the Right-of-Way Management Division office location during normal working hours or electronically if the applicant is registered with the Right-of-Way Office.

An application must include:

- (1) The name, address, telephone, and facsimile telephone number, if any, of the applicant or applicant's agent;
- (2) An emergency telephone number at which the applicant or person who intends to excavate may be contacted on a 24-hour basis;
- (3) The proposed beginning and ending dates of the excavation;
- (4) A schedule for restoration of the excavated portion of the right-of-way;
- (5) The proposed area of excavation, method of excavation, and location, including street address, cross streets, or other applicable description of the excavation location;
- (6) Proof of insurance and Performance/Assurance Bond as required by Chapter 20 of the City Code;
- (7) Proof that the owner has a franchise, consent, license, or other legal right to install facilities in a right-of-way, if the proposed activity involves installation of a facility;
- (8) Proof that the applicant is registered under Chapter 20 of the City Code, if applicable; and
- (9) A statement that the applicant has complied with applicable state and federal laws and regulations; and
- (10) Any other information required by the Director to evaluate and process the application.

In reviewing an application for a permit, the Director shall consider the following:

- (1) The size of surface and subsurface area to be affected, considering the type of excavation the applicant proposes;
- (2) The period of time the applicant proposes to occupy the area;
- (3) The safety of the pedestrian and vehicular traffic in and adjacent to the occupied area (traffic control); and
- (4) The vehicular and pedestrian traffic congestion and the vehicular parking requirements at the location.

4.2.3 DENIAL OF EXCAVATION PERMIT

A right-of-way use permit can be denied or suspended for any of the reasons outlined in Section 20 of the City Code of the City of Live Oak:

4.2.4 REVOCATION OF EXCAVATION PERMIT

The Director may suspend or revoke a permit if the permit holder fails to correct any violation or the Director determines that the violation creates an imminent danger to health or safety.

4.2.5 APPEAL OF DENIED EXCAVATION PERMIT

Refer to Chapter 20 of the City Code for appeal process.

4.3.0 OTHER APPLICABLE COSTS

The right-of-way user is responsible for cleaning up the area on or around the utility cut after the restoration and repairs have been completed (within 24 hours). In the event it is necessary for the CITY to clean up any area as a result of an right-of-way user's action, lack of action in a timely manner or negligence, the cost for this work will be billed to the right-of-way user at cost plus 10% Administrative Fee. This cost shall include, but not be limited to, labor (including overtime), equipment, fuel, material, supplies and contractual services necessary to complete the work.

4.4.0 EXCAVATION, JACKING, AND BORING IN THE PUBLIC RIGHT-OF-WAY

4.4.1 GENERAL

Excavation in any street not scheduled for reconstruction, paving, repaving or resurfacing should be kept to a minimum. The Permit Holder shall complete final pavement restoration of the excavated area within set time limit of the permit.

The Permit Holder shall conduct the work with a minimum disturbance of existing utilities and it shall be the responsibility of the Permit Holder to coordinate all work in or near the existing utilities with the right-of-way users.

All excavated materials or spoils deemed unsuitable for backfill material or determined as not required shall be removed within 24 hours. Such materials shall at no time be placed within cross section of sidewalk or travel way.

4.4.2.1 Blasting: Where permitted, blasting shall be performed in accordance with appropriate criteria established by the National Fire Protection Association [31 TAC 213.5 (3)(F)] and all Local, County, State, and Federal codes and ordinances. The Permit Holder shall be responsible for obtaining all permits as required prior to commencement of any work. Blasting must be done in such a manner as to minimize the fracturing of rock beyond the required excavation.

The Permit Holder shall consider the elevation of utilities in relation to the blasting charge and the relative alignment of existing and proposed trenches. Blasting within such areas shall be accomplished only by qualified Contractors who hold blasting licenses from a qualified agency such as the Live Oak Fire

Department. Any damage to existing utilities, infrastructure, etc., shall be repaired at the Permit Holder's expense. Sand shall not be used for bedding for backfill in trenches that have been blasted.

4.4.2.2 Trenching: Trench walls shall be vertical and the practice of undercutting at the bottom or flaring at the top will not be permitted except where it is justified for safety or at the Director's direction. In special cases where trench flaring is required, the trench walls shall remain vertical to a depth of at least one foot (1') above the top of the pipe. The trench bottom shall be square or slightly curved to the shape of the trenching machine cutters. The trench shall be accurately graded along its entire length to provide uniform bearing and support for each section of pipe installed upon the bedding material. Bell holes and depressions for joints shall be dug after the trench bottom has been graded and bedding installed. The pipe shall rest upon the new bedding material for its full length. Where over-excavation occurs, the under-cut trench shall be restored to grade at no cost to the City by replacement with a material conforming to the requirements of the bedding material or a material approved by the Director.

4.4.2.2.1: Minimum Width of Trench. The minimum width of pipe trenches, measured at the crown of the pipe, shall be not less than 12 inches greater than the exterior diameter of the pipe, exclusive of bells. The minimum base width of such trench shall be not less than 12 inches greater than the exterior diameter of the pipe, exclusive of special structures or connections. Such minimum width shall be exclusive of trench supports and not greater than the width at the top of the trench.

4.4.2.2.2: Maximum Width of Trench. The maximum allowable width of trench for pipelines measured at the top of the pipe shall be the outside diameter of the pipe (exclusive of bells or collars) plus 24 inches. A trench wider than the outside diameter plus 24 inches may be used without special bedding if the Permit Holder, at no expense to the City, furnishes pipe of the required strength to carry additional trench load. Such modifications shall be submitted to the Director and approved in writing prior to commencement of any work. Whenever such maximum allowable width of trench is exceeded, except as provided for on the drawings, or in the specifications, or by the written approval of the Director, the Permit Holder, at no expense to the City, shall cradle the pipe in geotextile fabric material, concrete, or other pipe bedding material approved by the Director. Any excavation wider than this maximum width will be done at the Permit Holder's expense including surface work.

4.4.2.2.3: Narrow Trench. Narrow excavations (i.e. trench widths less than 8") shall be backfilled with Controlled Low Strength Material (Section 4.8.5) or Class "J" Portland cement PCC (Standard Specification Item No. 300.1) and finished with an asphaltic concrete surface layer (Standard Specification Item No. 205).

4.4.2.3 Dewatering: Prevent surface water and subsurface or groundwater from flowing into excavations and from flooding project site and surrounding area.

1. Do not allow water to accumulate in excavations or at subgrade level. Remove water to prevent softening of foundation bottoms and soil changes detrimental to stability of subgrades and foundations. Provide and maintain dewatering system components necessary to convey water from excavations.
2. Convey water removed from excavation and rainwater to collecting or runoff areas away from buildings and other structures. Establish and maintain temporary drainage ditches and other diversions outside excavation limits. Do not use trench excavations as temporary drainage ditches.
3. Dewatering devices shall be provided with filters to prevent the removal of fines from the soil. Should the pumping system draw fines from the soil, the Right-of-way Management Inspector shall order immediate shutdown, and remedial measures will be the responsibility of the Permit Holder.
4. Upon completion of the dewatering work, the Permit Holder shall remove all equipment and leave the construction area in a neat, clean, and acceptable condition.
5. Maintain ground water table at least 12 inches below the finished excavation subgrade.
6. Dewatering Performances. Performances of the dewatering system for lowering ground water shall be measured by observation wells on piezometers installed in conjunction with the dewatering system, and these shall be read at least daily. The Permit Holder shall maintain a log of these readings and submit them to the Director.
7. All de-watering activities shall comply with the City's National Pollution Discharge Elimination System (NPDES) permit. No de-watering activity is authorized in the Municipal Separate Storm Sewer System (MS4) without the authorization by the Storm Water Division of the Department of Public Works.

4.4.2 EXCAVATION IN PORTLAND CEMENT CONCRETE (PCC) PAVEMENT SURFACE

If the existing pavement is Portland Cement Concrete (PCC), the concrete shall be cut first with a saw to a minimum depth of half the thickness of the concrete. The concrete can then be broken out with an air chisel or pavement breaker. Care shall be taken so as not to break back more than 6" of PCC beneath the saw cut. Expansion joints utilizing a $\frac{3}{4}$ expansion joint are required at each joint.

4.4.3 JACKING AND BORING

Where utilities are to be installed under a roadway by jacking or boring, the operation is to be inspected by the City. The following guidelines are identified for a jacking and boring (City of San Antonio Standard Specification Item No. 406) operation.

Construction operations will be conducted in such a manner that they will not weaken, impair or damage the existing roadway and infrastructure. The Permit Holder is responsible for determining the vertical and horizontal location of any facilities with the jacking or boring operation. Care must be taken not to damage other utilities. Pothole locates must be included in the scope of work as to location (street/parkway) and are

considered excavation.

The location of the boring pits shall be sufficient distance from the roadway to prevent undermining of the curb and gutter or shoulder. The City shall approve the location of the bore pit.

Bore pits shall be excavated to a depth sufficient to maintain a minimum depth of 36 inches from the surface to the top of the bore. Water jetting types of boring equipment will not be permitted.

The jacking or boring shall be in accordance with the City of San Antonio Standard Specification Item 406, "jacking or boring pipe". Clear space between the casing and the surrounding excavation shall be completely filled by pressure grouting the entire length of the installation.

Provide grout with a consistency that will flow into and completely fill all voids.

The pits or trenches excavated to accomplish this operation shall be backfilled immediately after the work has been completed. The backfill shall be compacted to a density equal to the requirements of applicable specifications of the City of San Antonio Standard Specifications and a backfill inspection will be required.

Bore pits shall not remain open at the end of any day. They shall be temporarily backfilled and plated or shall be fenced off by a 6 ft high chain link fence as per City of San Antonio Standard Spec. 507.2.

In addition, bore pits in excess of 4' may be required to utilize temporary traffic barriers and must conform to Section 6F.66 Longitudinal Channeling Devices of the Texas Manual of Uniform Traffic Control Devices.

4.4.4 RESPONSIBILITY OF EXCAVATED AREA MAINTENANCE

The Right of Way Ordinance states that, "All excavations shall be repaired in such a way so as not to become depressed, cracked, or broken or in any way fail during the remaining 'Life of the Street.' The remaining 'Life of the Street' for this purpose shall be until the subject area is repaved by the City or other entity." Any subsequent work performed in the street shall have all maintenance responsibility then transferred to the entity performing work in the same area.

Notwithstanding remediation of the pavement structure by City or other entity, the ROW user retains repair responsibility at all times for the trench envelope.

4.4.5 SHORING AND STEEL PLATES

The excavation and shoring of all trenches shall be in accordance with the "Trench Excavation and Safety Protection" required by Item 550, "Trench Excavation and Safety Protection", Item 400, "Excavation, Trenching and Backfilling" and Item 551, "Special Shoring" of the City of San Antonio Standard Specifications for Construction.

If trenches are not permanently backfilled by the end of the working day, the permit holder shall shore if needed and plate the trench. The plates if located in the street shall be secured by applying Hot Mix Asphaltic Concrete, Cold Laid around the perimeter of the plate. At no time shall the plates be placed in such a manner that causes a traffic hazard to pedestrians, cyclists and other non-vehicular traffic. Traffic control devices shall be installed and maintained in accordance with the Texas Manual on Uniform Traffic Control Devices (TMUTCD).

Steel plates shall not be removed prior to final asphalt restoration before 72 hours of scheduled placement of asphalt material.

4.4.6 RESPONSIBILITY FOR SIGNS, BARRICADES AND WARNING DEVICES The right-of-way User working in any public rights-of-way is responsible for the safe movement of traffic (pedestrian and/or vehicular) through the construction area. Right-of-way users shall meet all requirements for barricading and traffic control as specified in the Texas Manual on Uniform Traffic Control Devices (TMUTCD).

- A) Only those individuals, who are certified in safe traffic control practices and have a basic understanding of the principles established by applicable standards and regulations, including those in TMUTCD, should place and maintain the traffic control devices in construction area.
- B) If the right-of-way user does not subcontract the barricading to a firm specializing in traffic control, then they must have a certified person(s) and must submit the qualifications and name(s) of employees to the Right-of-Way Management Office for approval prior to the work commencing. They must also at this time submit for review a traffic control plan that demonstrates proper barricade placement as required in the TMUTCD.
- C) All barricades used by the right-of-way user shall be of the type, size and

design specified by TMUTCD. If a firm specializing in traffic control does not supply traffic control devices, then devices must be inspected and approved by the Right-of-Way Management Office.

- D) All traffic control devices must display accurate information describing the exact road situation.
- E) If the Director finds non-compliance with the TMUTCD, he will notify (in writing) the right-of-way user of the violation. If the right-of-way user ignores the citation, then the Right-of-Way Management Office will employ a contractor to properly place the devices. The CITY will pay the charges but the Right-of-way User must reimburse the CITY for all expenses plus \$600.00 for non-compliance. Failure to clear all charges will be sufficient grounds for denying the subsequent right-of-way use permits.

All traffic control devices must be removed immediately upon completion of work. Traffic Control devices (i.e. barricades, signs, cones, etc.) left on ROW past 24 hours of completion of work will incur a violation to be assessed in accordance with the ordinance until they are removed. Any traffic control devices left remaining in the right-of-way for ongoing work must not be visible to the traveling public unless required. This can be accomplished by bagging or placing signs face down. Traffic control devices must not at anytime be located within pedestrian walkway.

Prior to commencement of utility excavation, construction or any work associated with a permitted project; the right-of-way user shall install, erect or mount the following signs:

- 1) 48" x 30" (min.) (TxDOT Standard Sign No. G20-6) Contractor's informational sign containing the (i) name of the Contractor; (ii) Contractor's emergency phone number(s); (iii) right-of-way user, and (iv) estimated completion date. Other information could be provided on the sign that would provide the general public contractor related data. This sign shall be clearly displayed minimum one (1) per block. The sign shall be clearly displayed and maintained for the duration of the project.
- 2) 72" x 48" (min.) (TxDOT Standard Sign No. G20-8) right-of-way user informational sign containing the (i) name of the right-of-way user; (ii) Address; (iii) City; (iii) State; (iv) right-of-way user emergency phone number(s); and (iv) estimated start and completion dates. Other information could be provided on the sign that would provide the general public project related data. This sign shall be clearly displayed minimum one (1) per project (terminus end of project). The sign shall be clearly displayed and maintained for the duration of the project.

4.4.7 Utility Projects

Projects are defined as any installation, replacement, repair, rehabilitation or removal of an underground utility that extends over an area equal to or greater than fifty lineal feet. Pipe bursting and CIPP projects shall be in accordance with this section and shall be considered projects because of the excavation required for entry/exit pits and/or service reconnects.

Plans should be submitted for review at 50% completion and a walk-thru may be held. The Right-of-Way Management Division will submit their comments within two weeks of receipt. Plans shall be submitted again at 95% completion. Right-of-Way Management shall submit comments within one week of receipt. Prior to submission of any permit request, the 100% plan set shall be submitted and a site coordination meeting shall be scheduled.

The following items must be provided prior to approval of permits:

- A traffic control plan, including any detours
- Plans sheets depicting the pit locations and/or service reconnect excavations for Pipe Bursting and CIPP projects only.
- Staging area plan agreement letter from property owner, if applicable.
- A copy of the Project Advisory Notification used to notify local businesses and residences.
- A copy of the video.
- By-pass plan.

The ROW Utility Coordinator will generate a Letter of Provisions within 48 hours after the coordination meeting. This letter will provide the number of permits required, approval or denial of traffic control plan, trench and pavement restoration required, working hours and any other instruction(s) deemed necessary. This letter shall be signed by the Permit Holder/Requestor and returned to the Utility Coordinator. Permits may be requested upon receipt of signed letter.

Pipe Bursting and CIPP Projects will not be required to submit plans for 50% and 95% review but must still adhere to the requirements following the submission of the 100% plan set. These types of rehabilitation projects may be granted permission to submit permits to clean and televise upon request at the site coordination meeting.

4.5.0 BACKFILL OF EXCAVATED AREA

4.5.1 GENERAL

Open Trenches located in the street or alley may be temporarily backfilled with all weather material for the convenience of the Permit Holder or for public safety. However, at least one (1) hour prior to beginning permanent backfill operations, the Permit Holder must call the Right-of-Way Division Office for a trench inspection. The Permit Holder will need

the permit number and location of the street cut before calling to request an inspection. No backfill will be considered acceptable unless this call has been received and the Inspector has an opportunity to inspect the backfill operation. Permit Holder may commence backfill operations one (1) hour after notifying the Right-of-Way Management Office. Backfill made prior to the scheduled one (1) hour notice will be deemed unacceptable and subject to violation. Undermining of the curb, driveway or sidewalk in excess of four feet shall be noted during trenching and will require removal and replacement of structure.

All excess water and mud shall be removed from the trench prior to backfilling. Any backfill placed during a rainy period or at other times, where excess water cannot be prevented from entering the trench, will be considered temporary and shall be removed as soon as weather permits. All disturbed base material or any base that has been displaced shall be removed and discarded

Where a trench has been improperly backfilled, as determined by the Right-of-way Management Office, or where settlement occurs, the identified section shall be excavated to the depth and length required to attain stable material, then refilled and

compacted to the grade and 95% compaction. The use of sand backfill shall not be allowed

During inclement weather, at the Director's discretion, backfill and flatwork inspections may not be provided. Any backfills or flatwork restorations made during such times will not be acceptable.

Backfill of a street with a PCI greater than or equal to 86 and backfill of a street in a bus lane will require each layer to be compacted to not less than 95% of the density as determined in accordance with Test Methods TEX-113-E and TEX-114-E. Flowable fill can be used as an option to the density requirement.

4.5.2 GRANULAR BACKFILL SUPPORTING INFRASTRUCTURE

Backfill shall start with bedding of granular material per utility requirements followed with compacted granular backfill as detailed in Exhibits 8-4, 8-5, and 8-6 herein.

Granular backfill shall consist of crushed limestone, crushed gravel, or open graded material and shall be compacted in place to ninety-five percent (95%) of maximum density at optimum moisture as determined by the Modified Standard Proctor Test.

Flowable Backfill when shown on the Permit shall be used for initial and secondary backfill. Flowable Backfill shall conform to the requirements of Item No. 413, "Flowable Backfill".

Backfill, which will support any portion of any sidewalk, driveway or roadway, shall be placed in uniform layers not to exceed six inches (6") in depth (loose measurement). Each layer shall be compacted to not less than 95% of the density as determined in accordance with Test Methods TEX-113-E and TEX-114-E. Each layer of backfill material shall be at the moisture content required to obtain the specified density and shall be compacted to that density by approved mechanical means. The use of wheel compactors will only be allowed with prior authorization from the Director. When wheel compactors are used, backfill lifts may be increased to 12 inches provided proper moisture content of the backfill material is maintained and the specified minimum density is achieved.

Testing may be required to validate that adequate compaction is being achieved. All testing will be at the expense of the Permit Holder. If the backfill does not meet the density requirements, the backfill will be considered unacceptable and shall be removed and replaced at the expense of the Permit Holder.

The use of flooding as a means of obtaining compaction of back fill shall not be allowed.

4.5.3 BACKFILL NOT SUPPORTING INFRASTRUCTURE

All exposed areas, which will not support any portion of a sidewalk, driveway or roadway, shall be restored to original condition or better prior to excavation.

4.5.4 UTILITY ADJUSTMENTS FOR CAPITAL IMPROVEMENT PROJECTS Utility adjustments for a Capital Improvement Project (CIP) shall be performed in advance of the project unless arrangements are made with the Director. Adjustments made in advance of the six month window require a right-of-way permit and will be subjected to ordinance and UECM requirements.

The Permit Holder shall call the City's Right-of-Way Management Division Department of Public Works one-hour prior to initiation of backfill operations. The Permit Holder will

perform all repair requirements as specified in this manual up to the finish base. Cold mix asphalt concrete (TxDOT Specification Item 334,
Page 32 of 86

“Hot Mix-Cold Laid Asphalt Concrete Pavement”) may be used in lieu of hot mix asphalt concrete (Standard Specification Item No. 205) over the finish base.

The Permit Holder shall be required to maintain the trench until a work order is issued authorizing the CIP construction to commence.

4.5.5 BACKFILL IN DRAINAGE EASEMENTS AND RIGHTS OF WAY

Utility construction, installation and maintenance activities within the drainage system should be coordinated through the Right-of-Way Management Division and Storm Water Division of the Department of Public Works. All Best Management Practices (BMPs) in accordance with the City’s National Pollution

Discharge Elimination System (NPDES) permit shall be enacted to ensure no contaminants enter the drainage system (MS4) during and after utility construction, installation or maintenance activities are concluded. A flood permit may be required.

4.5.6 STORM SEWER UTILITY BACKFILLING

Backfilling for storm sewers is divided into three (3) separate zones: (a) bedding: the material in trench bottom in direct contact with the bottom of the pipe; (b) initial backfill: the backfill zone extending from the surface of the bedding to a point one foot (1’) above the top of the pipe; and (c) secondary backfill: the backfill zone extending from the initial backfill surface to the top of the trench. Materials and placement for each of the zones shall be as described herein.

4.5.6.1 BEDDING

The existing material at the bearing level shall be removed and replaced to a minimum depth of six inches (6”) or one-eighth (1/8) or the outside diameter of the pipe/facility, whichever is greater, with bedding material. The bedding material shall extend up the sides of the pipe/facility sufficient to embed the lower quadrant of the pipe/facility. The bedding material shall be composed of well graded CA-6 or CA-7, crushed stone or gravel conforming to the following requirements unless modified by the Director.

4.5.6.1.1 OVER EXCAVATION

Where the trench bottom has been over excavated beyond the limits as defined in the Permit due to blasting or removal or unstable material, the pipe/facility shall be concrete encased. Encasement shall extend from the trench wall to trench wall and be a minimum of six inches (6”) above the top of pipe/facility.

4.5.6.1.2 REDUCED EXCAVATION

Where the trench bottom is not excavated in accordance with the specification due to rock or other hard under lying materials, then the pipe shall be concrete encased.

4.5.6.2 INITIAL BACKFILL

Initial backfill is defined as backfill having a thickness in its compacted state from the surface of the bedding to a point one foot (1’) above the top of the pipe/facility. Initial backfill shall consist of gravel which conforms to City of Live Oak Standard Specifications for Construction. Item 410.

For storm sewer lines up to 24 inches in diameter initial backfill material shall be placed in two (2) lifts. The first lift shall be spread uniformly and simultaneously on each side and under the bottom quadrant of the pipe/facility to the mid-point or spring line of the pipe. Placement of the first lift of initial backfill shall be

inspected and approved prior to placement of subsequent lifts. Additional lifts shall extend to a minimum of one foot (1') above the top of the pipe/facility. Additional lifts shall be evenly spread in a similar manner as the first lift. For diameters 24 inches and larger, initial backfill material shall be evenly and simultaneously spread alongside, under the lower quadrant the pipe and over the pipe/facility in twelve-inch (12") lifts to a point sufficient to a minimum of one foot (1') above the top of the pipe/facility. No material or hand compaction will be required on an approved initial backfill material when the pipe/facility diameter is less than thirty-six (36") inches. Initial backfill shall be mechanically or hand compacted in all other conditions.

4.5.6.3 SECONDARY BACKFILL

After the initial backfill has been completed to a point 12 inches above the top of the pipe/facility by one of the methods outlined above, suitable rolling equipment may be used on these portions which are accessible to such equipment to obtain the compaction effect. Material for secondary backfill shall be placed in uniform layers no more than 12 inches in depth (loose measurement) and shall be compacted to the density specified herein. Each layer of secondary backfill material, if dry, shall be wetted uniformly prior to placement in the trench to the moisture content required to obtain the specified density, and shall be compacted to the required density by means of rolling equipment or other suitable mechanical method. No rolling equipment shall be used which may damage the utility.

A filter fabric shall be placed between the gravel backfill (initial backfill) and secondary backfill. Refer to Section 4.8.8 for filter fabric specifications.

Flowable Backfill when shown on the Permit shall be used for initial and secondary backfill. Prevent the pipe or structure from being displaced during the placement of the flowable fill, and prevent flowable backfill from entering culverts and drainage structure. Flowable Backfill shall conform to the requirements of Item No. 413, "Flowable Backfill".

4.5.7 SANITARY SEWER AND WATER UTILITY BACKFILLING

Backfilling for sanitary sewers and water mains is divided into three (3 separate zones: (a) bedding: the material in trench bottom in direct contact with the bottom of the pipe; (b) initial backfill: the backfill zone extending from the surface of the bedding to a point one foot (1') above the top of the pipe or infrastructure not to exceed 18"; and (c) secondary backfill: the backfill zone extending from the initial backfill surface to the top of the trench. Materials and placement for each of the zones shall be as described herein.

4.5.7.1 BEDDING

The existing material at the bearing level shall be removed and replaced to a minimum depth of six inches (6") or one-eighth (1/8) or the outside diameter of the pipe, whichever is greater, with bedding material. The bedding material shall extend up the sides of the pipe sufficient to embed the lower quadrant of the pipe. The bedding material shall be composed of well graded crushed stone or gravel conforming to the requirements set forth by the utility owner.

4.5.7.1.1 OVER EXCAVATION

Where the trench bottom has been over excavated beyond the limits as defined in the Permit due to blasting or removal or unstable material, the pipe shall be concrete encased. Encasement shall extend from the

trench wall to trench wall and be a minimum of six inches (6") above the top of pipe.

4.5.7.1.2 REDUCED EXCAVATION

Where the trench bottom is not excavated in accordance with the specification due to rock or other hard underlying materials, then the pipe shall be concrete encased.

4.5.7.2 INITIAL BACKFILL

Initial backfill is defined as backfill having a thickness in its compacted state from the surface of the bedding to a point one foot (12" not to exceed 18") above the top of the pipe. Initial backfill shall consist of gravel which conforms to San Antonio Water System Standard Construction Specifications. Item 410.

For lines up to 24 inches in diameter initial backfill material shall be placed in two (2) lifts. The first lift shall be spread uniformly and simultaneously on each side and under the bottom quadrant of the pipe to the mid-point or spring line of the pipe. Placement of the first lift of initial backfill shall be inspected and approved prior to placement of second lift shall extend from the spring line of the pipe to a minimum of one foot (12" not to exceed 18") above the top of the pipe or infrastructure. The second lift shall be evenly spread in a similar manner as the first lift.

For diameters 24 inches and larger, initial backfill material shall be evenly and simultaneously spread alongside, under the lower quadrant the pipe and over the pipe in 12 inch lifts to a point sufficient to a minimum of one foot (12" not to exceed 18") above the top of the pipe. No material or hand compaction will be required on an approved initial backfill material when the pipe diameter is less than thirty-six (36") inches. Initial backfill shall be mechanically or hand compacted in all other conditions.

4.5.7.3 SECONDARY BACKFILL

After the initial backfill has been completed to a point 12 to 18 inches above the top of the pipe by one of the methods outlined above, suitable rolling equipment may be used on these portions which are accessible to such equipment to obtain the compaction effect. Material for backfill shall be placed in uniform layers no more than 12 inches in depth (loose measurement) and shall be compacted to the density specified herein. Each layer of backfill material, if dry, shall be wetted uniformly prior to placement in the trench to the moisture content required to obtain the specified density, and shall be compacted to the required density by means of rolling equipment or other suitable mechanical method. No rolling equipment shall be used which may damage the utility.

A filter fabric shall be placed between the gravel backfill (initial backfill) and secondary backfill. Refer to Section 4.8.8 for filter fabric specifications.

Flowable Backfill may be used for secondary and final backfill. Prevent the pipe or structure from being displaced during the placement of the flowable fill, and prevent flowable backfill from entering culverts and drainage structure. Flowable Backfill shall conform to the requirements of Item No. 413, "Flowable Backfill".

4.5.8 BACKFILL UNDER STREETS STABILIZED WITH GEOGRID

All locations in which geogrid is determined to be in place will use flowable fill for backfill purposes.

4.6.0 RESTORATION OF EXCAVATED AREA

Except as otherwise provided by law, a person who excavates a street, sidewalk, driveway or drainage structure shall pay the City's cost to inspect. On completion of a permitted activity, a permit holder shall restore and maintain the right-of-way to its original condition or better in accordance with the procedures and time period prescribed in the Utility Excavation Criteria Manual, as determined by the Director.

Upon inspection, the Director may cause for the completion and restoration of the permitted work area. This work shall be billed to the right-of-way user, or apply the security, for the entire cost, if the permit holder does not finish the excavation within four (4) weeks after the Director makes a final inspection.

If the Director determines that the owner has not restored the right-of-way as required by this Manual or that the restoration is not complete, the Director may restore the area to the condition that existed before the permitted activity. The City may recover from the permit holder and the owner, jointly and severally, the actual expenses incurred in the restoration including, the cost of labor, materials, overhead, rental of equipment used in restoring the site, \$600.00/day penalty and attorney's fees. The City may institute procedures to forfeit bonds or other security furnished in connection with the permit.

4.6.1 GENERAL

The following requirements shall govern the restoration of street and alley pavements and easements in the City of Live Oak. On a CIP project, if there is a conflict between the following requirements and the CIP Plans and Project Manual, the Plans and Project Manual for the CIP project shall govern.

4.6.2 PERMANENT PAVEMENT REPAIRS

All permanent pavement repairs shall be made using one of the two following methods.

4.6.2.1 PERMANENT PAVEMENT REPAIRS BY CITY

If the City is to make the permanent pavement repairs, the Permit Holder shall maintain the excavated area for a period of two (2) weeks after acceptance by the Director. After the two-week period, the City will be responsible for maintaining the excavated area until final restoration is made. Backfill failures are still the responsibility of the Permit Holder. The Permit Holder shall reimburse the CITY for all costs incurred plus a 10% Administrative Fee.

4.6.2.2 PERMANENT PAVEMENT REPAIRS BY PERMIT HOLDER

If the Permit Holder is authorized to make permanent pavement repairs, the Permit Holder will maintain the excavated area until permanent pavement restoration of the excavated area is complete. The Permit Holder shall make final repairs within permit expiration date. Backfill failures that are not caused by other utilities action are still the responsibility of the Permit Holder.

4.6.3 Flatwork

Permits shall call for inspection prior to placement of concrete. Inspection of prepared section shall be made within one hour of call. Approval of the flatwork inspection grants the Permit Holder permission to place the concrete in accordance with Section 4.6.7 and 4.6.8.

4.6.3.1 EXCAVATION UNDER CURB OR CURB AND GUTTER

If the excavation occurred under the existing curb and gutter and undermines more than four feet (4') of the curb line, the undermined curb and gutter shall be removed and replaced to the nearest joints on each side of the cut.

All curb or curb and gutter with visible signs of damage or movement caused by Permit Holders activities shall be removed and replaced. Concrete and CLSM used shall be in accordance with City of Live Oak Standard Specifications.

4.6.3.2 EXCAVATION UNDER SIDEWALK

If the excavation occurred under an existing sidewalk, the sidewalk shall be removed back to the nearest expansion or dummy joint beyond the trench wall and replaced after the work is completed. Concrete used shall be in accordance with City of San Antonio Standard Specifications for sidewalks (Standard Specification Item 502, "Concrete Sidewalks") and meet ADA requirements.

4.6.3.3 Excavation Under Driveway

If the excavation occurred under an existing driveway, the driveway shall be removed back to the nearest expansion or dummy joint beyond the trench wall and replaced after the work is completed. Concrete used shall be in accordance with City of San Antonio Standard Specifications for sidewalks (Standard Specification Item 502, "Concrete Sidewalks") and must meet ADA requirements unless otherwise directed.

4.6.4 CURB AND GUTTER

Replacement curb and gutter will be set true to grade. The replacement curb and gutter shall be Class "A" concrete (Standard Specification Item No. 300.1) with finish mortar to be applied within one (1) hour of placement of the concrete. The curb and gutter shall be placed on a minimum of four inches (4") of compacted base. It shall be formed with "mules" and "S" trowels. Expansion joints, ½ inch wide expansion joint material, shall be placed at intervals not to exceed 40 feet. Weakened plane joints shall be made ¾ inch deep and placed at ten-foot (10') intervals. The edges of all joints shall have a ¼ inch radius. All replacement curb or curb and gutter shall be constructed to the nearest expansion or dummy joint of the existing curb and gutter. If removed to a weakened plane joint, two 24 inch smooth dowels, ½ inch in diameter shall be inserted a minimum of 12 inches into the existing curb. A minimum of one (1") inch gap shall be provided at the end of the drilled hole.

4.6.6 SIDEWALKS

Replacement sidewalks shall be Class "A" Concrete (Standard Specification Item No. 300.1) matching the existing thickness but with a minimum thickness of four inches (4") in residential areas and five inches (5") in commercial areas. Gravel base or crushed rock, except that the width and location shall match the existing sidewalk. All sidewalk replacement shall be extended to the nearest expansion or dummy joint of the existing sidewalk. If a pole is present in the sidewalk, must provide a knockout around pole. Expansion joint material, that is ¾ inch in thickness and conforms to City of San Antonio Standard Specification Item No. 304, shall be placed at a distance not to exceed 48 or 50 foot intervals between joints and passing through the entire thickness of the concrete being placed. Weakened plane joints shall be made ¾ inch deep and placed at five feet (5') intervals. The edges of all joints shall have a ¼ inch radius. The concrete shall receive a broom finish unless the surface is to match an existing exposed aggregate surface.

Reinforcement shall match the existing in accordance with item City of San Antonio Standard Specification 301 or 303, but in no case shall it be less than one layer of 6x6 – welded-wire fabric or equivalent. It shall be supported such that it will be at the mid-depth of the slab. During the placement of concrete, care shall be taken that the reinforcement remains at this position. If the replacement sidewalk is matching an existing sidewalk at a weakened plane joint, then the reinforcement shall be lapped a minimum of six inches (6").

Concrete for sidewalks will be placed as soon as practical after the utility had been placed. Sides of sidewalks shall be backfilled immediately after forms are removed.

When a sidewalk is being replaced within the radius of a curb return at an intersection, a sidewalk Pedestrian Ramp will be installed.

Americans with Disabilities Act (ADA) Requirements related to pole clearance on sidewalks

- (A) Early in 2011, it is projected that the national ADA right-of-way standards will require 48" of clearance on sidewalks. It is the City's goal to have 48" of sidewalk clearance when a Permit Holder is installing a pole.
- (B) It is the City's goal to eliminate poles in sidewalks. In areas where green space is available, reasonable efforts will be made by the Permit Holder to place the pole in the green space.
- (C) If 48" of sidewalk clearance cannot be achieved, then 36" will be allowed. Documentation should be provided which include the locations and condition.
- (D) If 36" of sidewalk clearance cannot be achieved, then options such as acquiring additional right-of-way, "bubbling" curb into street or widening the sidewalk width, or relocating pole(s) will be considered to increase the amount of available sidewalk space.
- (E) The City will approve poles in sidewalks with less than 36" of clearance if it is mutually determined by both the City and the Permit Holder, that there are no feasible alternatives for providing 36" clearance.
- (F) Poles will be allowed in sidewalks as long as they meet the above conditions. Poles in sidewalks shall be permitted as non-standard and shall be in accordance with Sec 29-138 of the Right-of-Way Ordinance.
- (G) Guy wires supporting poles should not be anchored within the 48" clear width.
- (H) Appropriate guy wire treatment should be installed to protect visually impaired persons from hazards of running into them.

- (I) The City strives to provide sidewalk accessibility as a goal and that coordinated efforts will be made to ensure that sidewalk accessibility is provided.

4.7.0 PAVEMENT REPAIRS

4.7.1 GENERAL

The following requirements shall govern the replacement of the pavement structure whether the work is to be done by the Permit Holder or the City.

The Permit Holder must notify the Right-of-Way Division of the Public Works Department at least one (1) hour prior to beginning the permanent pavement repair. If the Inspector has not arrived within one (1) hour of the notification, the pavement repairs may proceed and does not constitute an automatic approval of same.

4.7.2 SURFACE PREPARATION

When the Permit Holder is performing only temporary surfacing – The backfill will be topped with a minimum compacted thickness of two inches (2”) of hot mix-laid or hot mix-cold laid asphalt concrete or asphalt treated base all weather surface material.

When a Permit Holder is to provide the final surfacing – the backfill shall be topped with a minimum thickness of two inch (2”) Type “D” HMAC Mix for local/residence streets or a minimum thickness of three inch (3”) Type “C” Modified HMAC Mix for major/minor streets or match existing pavement.

All final pavement cuts shall be made with a saw to straight and uniform lines. Trench restoration shall include resurfacing to a constant width equal to the widest part of the excavation plus 12 inches on each side. On longitudinal cuts a line parallel to the curb shall be used to mark the widest part of the excavation plus 12 inches. A perpendicular line to the curb line plus 12 inches at each end shall mark the length of the excavation.

On transverse cuts, the restoration area shall be a line perpendicular to the curb line and starting at a point of 12 inches from the wall of the trench at the widest point.

Areas with widths of 24 inches or less between the edge of the curb and the repair surface will also be removed.

All damage caused directly or indirectly to the street surface or subsurface outside the pavement cut area shall be regarded as a part of the street cut. This includes any holes drilled into the pavement and not properly plugged, or gouges caused by equipment. These areas, as established by the Director, shall be included in the total area repaired. All damaged survey markers or benchmarks within the excavation shall be replaced. All traffic devices damaged during the excavation shall be replaced as part of the restoration.

4.7.3 FLEXIBLE BASE WITH ASPHALT SURFACE

When existing pavement consists of flexible base with an asphalt surface, the permanent pavement repair shall be made in accordance with this procedure and Standard Drawing No. 8.4.

All disturbed base material or any base that has been undermined shall be removed and discarded.

All exposed edges and surfaces shall be tack coated (City of San Antonio Standard Specification Item No. 203) before placing the new asphalt concrete. The new asphalt concrete shall be placed and compacted flush with the existing surface at the thickness of the existing asphalt surface but in no case shall it be less than two inches (2”) thick for local/residential, and no less than three (3”) for major/minor.

4.7.4 ASPHALT OVERLAY ON PORTLAND CEMENT CONCRETE (PCC) SURFACE

When the existing pavement consists of PCC with an asphalt overlay surface, the permanent pavement repair shall be made in accordance with this procedure and Standard Drawing Nos. (existing non-reinforced PCC) and (existing reinforced PCC).

If the existing concrete base or pavement contains reinforcing steel, the existing concrete shall be cut with a saw six inches (6") beyond the edges of the cut and broken out without any damage to the reinforcing steel or remaining concrete. The depth of saw cut shall be at least ½ the thickness of the concrete base. Replace reinforcing steel of the same size and Grade 40. Reinforcing steel shall be firmly tied to the existing steel with six-inch (6") laps. If the reinforcing steel is cut or broken off during this operation, the replacement steel shall be butt-welded by a certified welder.

All PCC shall be Class "A" (City of San Antonio Standard Specification Item No. 300.1) and shall extend from two inches (2") below the existing PCC pavement to the asphalt surfacing but in no case shall it be less than seven inches (7") in thickness. The concrete shall be consolidated

by vibration and receive a wood-float finish. The concrete may be rodded for small placements of concrete in lieu of vibrating. The concrete shall be cured for a minimum of seventy-two (72) hours, or as approved. Traffic shall not be allowed to cross the concrete during this 72-hour period.

After the PCC has cured and all the edges of the existing asphalt surfacing have been tack coated (City of San Antonio Standard Specification Item No. 203), the new asphalt concrete shall be placed and compacted flush with the existing surface. The new asphalt surface (City of San Antonio Standard Specification Item No. 205) shall be the thickness of the existing asphalt surface but in no case shall it be less than two inches (2") Type "D" HMAC Mix for local/residential streets nor less than 3 inches (3") Type "C" HMAC Mix for collector, minor arterial and major arterial streets.

4.7.5 FULL-DEPTH PORTLAND CEMENT CONCRETE (PCC) SURFACE When the existing pavement consists of full-depth PCC construction, the section excavated shall be replaced from joint to joint. Follow the requirements of City of San Antonio Standard Specification Item No. 209 Concrete Pavement and Standard Specification Drawing Nos. 4.5 (existing non-reinforced PCC) and 4.6 (existing reinforced PCC).

If the existing concrete base or pavement contains reinforcing steel, the existing concrete shall be cut with a saw six inches (6") beyond the edges of the cut and broken out without any damage to the reinforcing steel or remaining concrete. The depth of saw cut shall be at least ½ the thickness of the concrete base. Replace reinforcing steel of the same size and Grade 40, min. Reinforcing steel shall be firmly tied to the existing steel with six-inch (6") laps, min. If the reinforcing steel is cut or broken off during this operation, the replacement steel shall be butt-welded by a certified welder.

The new PCC shall be Class "A" (City of San Antonio Standard Specification Item No. 300.1) and shall extend from two inches (2") below the existing PCC to flush with the surface of the existing concrete. In no case shall the new concrete be less than seven inches (7") in thickness. The concrete shall be consolidated by vibration and receive a wood-float finish. It shall be cured for a minimum of 72 hours. Traffic shall not be allowed on the concrete surface during this 72-hour period.

All disturbed base material and all asphalt concrete that has been undermined shall be

removed and replaced with Class "A" Concrete (Standard Specification Item No. 300.1),
Page 41 of 86

to the depth of the asphalt concrete but in no case less than seven inches (7") thick. The PCC will be consolidated by vibration and receive a wood-float finish. The concrete shall be finished two inches (2") below the existing asphalt surface. The concrete shall be cured for a minimum of 72 hours or as allowed by the Director for quickset mixes. Membrane curing will not be allowed. Traffic shall not be allowed to cross the concrete during the curing period.

4.7.6 FULL-DEPTH ASPHALTIC CONCRETE PAVEMENT

When the existing pavement consists of "Full-Depth" asphaltic concrete, the permanent repair shall be made in accordance with this.

The existing full depth asphalt pavement shall be cut with a concrete saw a distance of 12 inches beyond the edges of the trench wall and the resulting isolated asphaltic materials shall be broken and removed. The depth of the saw cut shall be at least ½ the thickness of the pavement thickness. The top two inches (2") for residential streets or three inches (3") for major arterial, minor arterial and collector streets of the full depth asphalt pavement layer shall then be sawed a distance of twelve inches (12") beyond the excavation walls and the ACP materials removed.

All disturbed sub-base and subgrade materials that have been undermined shall be removed and replaced with compacted backfill to the bottom of the existing full depth asphalt pavement section. The top surface of the compacted backfill shall be primed in accordance with City of San Antonio Standard Specification Item No. 202. A tack coat (Standard Specification Item No. 203) shall then be applied to the exposed vertical edges and top of the primed surface.

The new roadway base structure shall consist of Hot Mix Asphaltic Concrete Type "A". The rate of application shall be designed by a Professional Engineer for repairs in excess of 100 square yards. Projects of 200 square yards or less may use the following rates of application: 5" for Residential/Local Streets; 7" for Collector Streets; 8" for Minor Arterial Streets and 9" for Major Arterial Streets.

The new asphalt surface (Standard Specification Item No. 205) shall be the thickness of the existing asphalt surface but in no case shall it be less than two inches (2") Type "D" HMAC Mix for local/residential streets and 3 inches (3") Type "C" modified HMAC Mix for collector/arterial streets. The asphalt concrete shall be compacted in accordance with Standard Specification Item No. 205.

4.7.7 REPAIR OF STREETS AND/OR TRENCHES

Narrow excavations, with a trench width less than eight inches (8"), shall be backfilled with Controlled Low Strength Material (Section 4.8.5) or Class "J" Portland cement PCC (City of San Antonio Standard Specification Item No. 300.1) and finished with an asphaltic concrete surface layer (Standard Specification Item No. 205). Narrow cuts adjacent to existing Curb and Gutter shall be completed in accordance with this procedure, while narrow cuts along and across the roadway shall be completed in accordance with this procedure.

Excavations with trench widths greater than eight inches (8") shall be backfilled in accordance with Standard Drawing 8.4.

The designation of a Class "J" PCC is intended to identify the relative in-place strength of the desired material. Concrete mixes greater than a two-sack mix will not be allowed in these applications.

If the excavation is transverse (crossing the street), the existing surface shall be saw cut a minimum of 12 inches wider on each side of the trench wall and replaced with new equivalent surfacing.

Longitudinal excavation parallel to the curb and gutter shall require removal and replacement of the existing surface layer a minimum of the width of the trench plus 12 inches on each side of the trench.

A narrow excavation that is parallel and adjacent to the curb and gutter shall be required to pave a minimum of 24" from the lip of the gutter. Twelve inches (12") from the outer trench wall shall be maintained at all times. Adjustment and increase in the 24" minimum pavement patch may be required.

Factors include excavations in close proximity to the curb, traffic, street classification, bus lanes, intersection, driveways, other pavement cuts, etc., shall require removal and replacement of an additional area of pavement. The Director may also require the replacement of a full lane to preserve the original condition of the street. If any portion of a trench repair in an asphaltic concrete pavement falls within a street intersection (i.e. from curb to curb return), then the entire quadrant of the existing surface layer shall be replaced, unless otherwise directed in writing by the Director. If the trench repair occurs within a PCC pavement, then the entire concrete slab from joint to joint and joint to edge shall be replaced, unless otherwise directed in writing by the Director.

All overlaid areas of streets with a pavement condition index (PCI) greater than or equal to 86 shall be milled (City of San Antonio Standard Specification Item No. 208) to provide a smooth transition.

The thickness of the pavement shall be consistent with the existing surface but in no case shall it be less than two inches (2") for residential streets or three inches (3") for collector, minor arterial and major arterial streets and match existing asphalt.

Backfill shall comply with Section 4.5.1 of this manual and City of San Antonio Standard Specification Item No. 400. A certified laboratory shall obtain density test for backfill material. All density tests shall be completed and approved on each layer prior to additional backfilling. A copy of all completed and approved density tests shall be furnished to City of Live Oak Public Works Department within 24 hours after completion of street repair. Permit holder is responsible for all associated cost with laboratory testing.

4.7.8 EXCAVATIONS PARALLEL AND NEAR TO THE CURB AND GUTTER When there is less than two feet (2') of existing pavement remaining between the excavation and the curb/gutter, this additional pavement shall be removed and the final surface restoration shall include the entire area to about the curb/gutter.

TYC modified for collector/arterial streets and TYD for local/residential streets.

When the length of an excavation in an asphalt pavement surface parallels the curb and gutter has an area of two feet (2') or less between the existing and new pavement, the area shall be removed and replaced with new surface.

Narrow excavation parallel and adjacent to the curb and gutter shall be paved a minimum width of 24 inches (24") from the lip of the gutter. The utility line will be enveloped with pipe bedding material in conformance with City of San Antonio Standard Specification Item No. 410, or approved pipe manufacturer bedding material

recommended for the facility

being installed. The remainder of the trench will be concrete capped to a depth below the lip of the gutter of two inches (2") for residential streets or three inches (3") for collector, minor arterial and major arterial streets. The surface shall be finished with an asphalt surface, Hot Mix - Hot Laid.

4.8.0 MATERIAL SPECIFICATIONS

4.8.1 GENERAL

All materials shall be described in this section and the City of San Antonio Standard Specification for Construction Items.

4.8.2 ASPHALT TREATED BASE

Asphalt treated base shall meet the requirements of Item 206, "Asphalt Treated Base", of the City of San Antonio Standard Specifications. Before using alternate materials and/or methods, written approval shall be required. The Director shall review the request and if approved for use, shall issue a written statement.

4.8.3 PORTLAND CEMENT CONCRETE (PCC)

Concrete, unless otherwise stated, shall meet the requirements of Item 307, "Concrete for Structure," of the City of San Antonio Standard Specifications for Class "A" concrete. The slump shall not exceed four inches (4"). Maximum time intervals from initial batching of the mix to the placement of concrete, as well as ambient temperature restrictions at the time of placement shall meet the requirements of Section 307, "Concrete Structures". Membrane curing or other approved methods shall be used to cure all concrete. Membrane curing shall not be permitted on a surface on which tack coat or asphalt concrete will be placed. Traffic shall not be allowed on new concrete of a minimum of seventy-two (72) hours.

Hand mixing of concrete shall be permitted only for small placements of under one (1) cubic yard or in case of an emergency. Hand mixed batches shall be proportioned with one (1) part cement to three (3) parts aggregate mixture by volume, and enough water to provide not more than a four inch (4") slump. Aggregate mixture shall consist of approximately two (2) parts gravel to one (1) part sand by volume.

4.8.4 ASPHALTIC CONCRETE PAVEMENT (ACP)

Asphaltic concrete shall meet the requirements of Item 205, "Hot Mix Asphalt Concrete Pavement", Type "C" modified or "D" of the City of San Antonio Standard Specifications unless another type is specified, and to a depth shown on the Drawings but not less than two inches (2") for residential streets or three inches (3") for collector, minor arterial and major arterial streets. The asphalt concrete shall have a temperature of not less than 200° F degrees when placed. It shall not be placed on ice, moisture or a frozen base.

Before placement of asphaltic concrete, all exposed surfaces shall receive a tack coat in accordance with Item No. 203, "Tack Coat", of the City of San Antonio Standard Specifications. The asphalt concrete shall be compacted flush with the existing surface to an in-place density of not less than 92% of maximum theoretical density.

Street excavations with a width of ten feet (10') or more will require the base to be primed in accordance with Items 202, "Prime Coat", of the City of San Antonio Standard Specifications. The asphalt concrete shall be placed with an approved heater-screened lay-down machine unless otherwise approved by the Director.

4.8.5 CONTROLLED LOW STRENGTH MATERIAL (CLSM; FLOWABLE FILL)

This specification identifies the basic requirements for furnishing, mixing and transporting Controlled Low Strength Material (Flowable Fill). Flowable Fill is a low

strength concrete material suitable as a backfill for utility trenches, abandoned pipes, manholes and valves. It is a heavy material and will exert a high fluid pressure against any forms, embankment or wall used to contain the Flowable Fill.

Materials shall conform to:

Cement	ASTM C150
Fly Ash	ASTM C618, Class "C" or Class "F"
Water	ASTM C94
Fine Aggregates	Natural or manufactured sand or combinations thereof, free from injurious amounts of salt, alkali, vegetable matter or other objectionable material. It is intended that the fine aggregate be fine enough to stay in suspension in the mortar to the extent required for proper flow. The fine aggregate shall conform to the following gradation:
SIEVE SIZE	PERCENT PASSING
3/4 inch	100
No. 200	0-10

If a flowable mixture cannot be produced, the sand may be rejected.

Admixtures - ASTM C260 and/or C494

Mix Design - The 28-day unconfined compressive strength must be less than 1,000 PSI, while three (3) day strength must exceed 25 PSI. The quantities of dry material per cubic yard are as follows:

WITH FLY ASH:		WITHOUT FLY ASH:	
Cement	50 lbs.	Cement	141 lbs.
Fly Ash	250 lbs.	Fine Aggregate	2,800 lbs.
Fine Aggregate	2,910 lbs.	Water	49.9 gals.
Water	60 gals.		

Consistency shall be tested by filling an open-ended three inch (3") diameter cylinder six inches (6") high to the top with flowable fill. The cylinder shall be immediately pulled straight up and the correct consistency of the flowable fill shall produce a minimum eight-inch (8") diameter circular-type spread with no segregation.

Batch, Mixing and Transportation – Materials are to be measured by weight and/or volumetric methods. The flowable fill may be mixed in a central concrete mixer, a ready mix truck, or by other acceptable methods. The flowable fill shall be transported to the point of placement in a revolving drum mixer or in an agitator unit.

Placing - For pipe trench backfill, provide bulkheads at units of fill placement sufficient to confine backfill. Bulkheads are to be structural.

CLSM may be covered when it adequately supports the weight of construction equipment, but no less than 24 hours after completion of placement. CLSM must be topped with ACP no less than 24 hours after plate removal.

4.8.6 GRANULAR MATERIALS

Granular materials furnished for foundation, bedding, encasement, backfill, or other purposes as may be specified shall consist of any natural or synthetic mineral aggregate such as sand, gravel, crushed rock, crushed stone, or slag, that shall be so graded as to meet the gradation requirements specified by the utility owner.

(a) If no standard is available from Utility Company, then the following standards shall be used:

Sieve Size	Percent Passing			
	Foundation	Bedding	Encasement	Backfill
3-inch				
2-inch				100
1-inch	100	100	100	
3/4-inch	85-100	90-100	90-100	
3/8-inch	30-60	50-90	50-90	
No. 4	0-10	35-80	35-80	35-100
No. 10		20-65	20-65	20-100
No. 40		0-35	0-35	0-35
No. 200		0-10	0-10	0-10

(b) Granular Material Use Designations. Granular materials provided for foundation, bedding, encasement, or backfill use as required by the plans, specifications, and special provisions, either as part of the pipe item work unit or as a separate contract item, shall be classified as to use in accordance with the following:

Material Use Designation	Zone Designation
Granular Foundation	Placed below the bottom of pipe grade as replacement for unsuitable or unstable soils, to achieve better foundation support.
Granular Bedding	Placed below the pipe mid-point, prior to pipe installation, to facilitate proper shaping and to achieve uniform pipe support.
Granular Encasement	Placed below an elevation one foot above the top of pipe, after pipe installation, for protection of the pipe and to assure proper filling of voids or thorough consolidation of backfill.
Granular Backfill	Placed below the surface base course, if any, as the second stage of backfill, to minimize trench settlement and provide support for surface improvements.

4.8.7 DRAINAGE FABRIC

Fabric shall be Amoco ProPex 4551 or approved equal. Storage and handling of fabric shall be in accordance with the manufacturer's recommendations except that in no case shall the fabric be exposed to heat or direct sunlight to the extent that its strength or toughness is diminished. Torn or punctured fabric shall not be used.

For a material to be considered an approved equal, the following material properties must be met or exceeded:

1. Puncture Strength (ASTM D4833) – 90 lbs.
2. Mullen Burst (ASTM D3786) – 310 psi

3. Trapezoidal Tear Strength (ASTM D4533) – 65 lbs.
4. UV Resistance (ASTM D4355) – 70% @ 500 hrs.

4.9.0 MISCELLANEOUS REPAIRS

If the Director determines that the owner has not restored the right-of-way as required by this division or that the restoration is not complete, the Director may restore the area to the condition that existed before the permitted activity. The City may recover from the permit holder and the owner, jointly and severally, the actual expenses incurred in the restoration including, the cost of labor, materials, overhead, and rental of equipment used in restoring the site. The City may institute procedures to forfeit bonds or other security furnished in connection with the permit.

4.9.1 EXCAVATION IN ALLEY

When Portland cement (PCC) is encountered; Standard Specification Item No. 209, "Concrete Pavement" shall be followed. Where no flexible base exists, 12" minimum of flexible base shall be placed for the width of the trench plus six inches (6") from perimeter walls. Where excavation occurs in vegetative cover alleys where no pavement or flexible base is present, alley backfilling specifications set herein are in affect to include restoration of the vegetative cover to previous conditions with a minimum of 100% coverage, original or better, in disturbed areas. Paved alley's are to be restored in accordance with same items governing street excavation and will adhere to all requirements for restoration based upon PCI determinations.

4.9.2 EXCAVATION IN DRIVEWAYS

When driveways are excavated on public rights-of-way, they shall be replaced "in-kind", i.e., an asphalt surface on a flexible base shall be replaced with similar materials to a similar depth. Any asphalt surface replaced shall be at least two inches (2") of asphalt concrete. A Portland cement concrete drive shall be replaced with Class "A" concrete (Standard Specification Item No. 300.1) to a similar depth as existing except that in no case shall it be less than five inches (5") on a two inch (2") flexible base - crushed rock gravel. Any curbing on the driveway that was damaged shall be replaced. Rebar is required, commercial 12" inch center #4, 100% tied or #3 or #4 welded fabric.

4.9.3 MANHOLES AND PULL BOXES

Permanent pavement repairs around manholes pull boxes, or similar structures shall be in accordance with Standard Drawing No. 8.5 for (City of San Antonio Standard Specification Item No. 403) manhole and Standard Drawing No. 8.8 (Standard Specification Item No. 603) for Pull Boxes or other designs as approved by the Director. The new pavement structure shall match the existing except that concrete base shall be at least nine-inch (9") thick. Asphalt stabilized base shall be at least eight inches (8"). Flexible base shall be at least 12" thick. Hot mix asphalt concrete pavement shall be at least two inches (2") thick for residential and three inches (3") thick for arterial.

4.9.4 TRAFFIC SIGNALS

Whenever any excavation is to be performed within five-hundred 500 feet of a signalized intersection, approval from the Public Works Department must be obtained prior to commencing the work, (210) 653-9140. The approval will be in the form of an agreement signed by the applicant and the representative from public works on a form depicting the intersection layout and traffic control utilities (loops, stub-outs, pull-boxes, conduits, etc.) that will be affected by the planned excavation.

The applicant must notify the Public Works Department no less than seventy-two (72) hours prior to commencing the work. The notification should include specific information pertaining to location, scope and duration of planned excavation.

The Public Works Department will subsequently determine if a joint meeting between the applicant and a Public Works Department representative needs to be held at the job site, wherein the Public Works Department will locate the existing traffic control utilities which may be affected by the scope of the planned work. Public Works Department will, subsequently, depict the located utilities on the back of a work order.

Forty-eight (48) hours prior to start of work, the applicant must notify Public Works Department to confirm start of work. Any modification or adjustment to signal operations deemed necessary by the Public Works Department will be planned upon receipt of this confirmation and implemented accordingly.

The applicant is responsible to repair or replace at their own expense and to the satisfaction of the Director, any damage to the traffic control resources including but not limited to vehicle loop detectors, home-runs, stub-outs, conduits, risers, ground boxes and cabinet. The right-of-way user must hire a firm specializing in the installation of traffic signals and have the signal restored to its original operational function. All materials, labor and procedure must be in accordance with the current City's traffic signal specifications and standards.

The applicant is responsible for all liability for personal injury and/or property damage resulting from damage to any of the traffic signal components caused by the applicant's activities should the applicant fail to notify the Public Works Department prior to start of work to request the Public Works Department to modify or adjust the programming parameters controlling the traffic signal operation if deemed necessary.

Should the proposed scope of work conflict with the existing traffic resources (signals, signs, markings), the right-of-way user is responsible to identify and implement any and all temporary measures (outside the traffic signal controller assembly) required to continue traffic control operations during construction in accordance with City's Traffic Signal specifications and standards and TMUTCD guidelines. These measures as well as the traffic management plan are to be approved by the City's Public Works Department.

If the Right-of-way User ignores the restitution of the signal, then the Director will make the correction. The right-of-way user must reimburse the City of all costs incurred including 10% Administrative Fee plus \$600.00 penalty per day per occurrence for non-compliance. Failure to clear all charges will be sufficient grounds for denying the next requested permit.

4.9.5 TRAFFIC MARKINGS

Traffic markings that were removed or damaged during the trenching or trench restoration processes must be replaced with thermoplastic as per the Uniformed Development Code.

The markings must be replaced immediately after the trench is completely restored. The right-of-way user must hire a firm specializing in the application of traffic markings and all

materials, labor and procedure must be according to the specifications of City. The Right-of-way User is responsible for all costs.

If the Right-of-way User ignores having the traffic marking replaced, then Director will have the missing or damaged markings replaced. The Right-of-way User must reimburse the City for all incurred costs including 10% Administrative Fee plus \$600.00 per day per occurrence penalty for non-compliance. Failure to clear all charges will be sufficient grounds for denying the next requested permit.

4.9.6 MONITORING WELLS

All parties requesting access from the City of Live Oak to install temporary monitoring wells for the purpose of assessing water quality, determining environmental impacts, etc. on City right-of-way shall first obtain a right-of-way use permit from the Department of Public Works. All requests to install temporary monitoring wells on City right-of-way shall be submitted to the Public Works Department with the following:

Right-of-Way Use Permit Application (Installation and Removal)

- a. Certificates of insurance from consultant's and/or or drilling contractors as prescribed in Chapter 20 inclusive of the City Code of the City of Live Oak.
- b. A site location map and plan showing locations(s) of proposed monitoring wells, in accordance with of the City Code of the City of Live Oak.
- c. A typical well construction diagram standard drawing No. 8.11 indicating the design of the well(s) and depth shall be completed in its entirety and submitted at time of application.
- d. Boring logs, sample results, chain of custody and sample locations for all samples collected in the monitoring wells, within a reasonable time after drilling the monitoring wells.

All monitoring wells shall be installed by a State of Texas licensed water well driller, and all applicable federal, state and local regulations. All monitoring wells shall be removed by the applicant upon termination of monitoring activities. A water well plugging report shall be submitted to the Public Works Director upon completion of removal. The City of Live Oak shall not, in any way, be held liable for any damages caused by the installation, use of, or removal of these wells. Any questions regarding temporary monitoring well installation requirements can be directed to the Storm Water Division of the Department of Public Works.

4.9.7 FIRE HYDRANTS

Each excavation shall be performed so it does not obstruct emergency access to any fire hydrant or public water supply valve.

4.9.8 AS-BUILT DRAWINGS AND SPECIFICATIONS

Upon final completion of an excavation, the permittee may be requested to provide the Director a set of as-built drawings and specifications for the excavation when the Horizontal and/or Vertical permitted alignment deviates more than 1.5 feet AND/OR a major deviation in materials used in the trench backfill and restoration. In the event that the work was performed in accordance with the permitted alignment - the permittee may forfeit the requirement to submit As-Built Drawings by advising the Director in writing. The previously supplied drawings and specifications will be regarded as the as- built drawings and specifications.

The Director shall initially review each as-built submittal to determine whether it is complete. The Director shall return an incomplete as-built submittal with an explanation of the deficiencies. A complete as-built submittal shall become effective as

a permit on the 14th day after the complete as-built submittal is received by the Director, unless the owner is notified that the permit has been disapproved.

The Director shall disapprove the as-built submittal if he determines that he conditions of this action are not satisfied. If an as-built submittal is disapproved, the Director shall notify the owner of the grounds for denial.

4.9.9 BILLING PROCEDURES AND FEES

Fees will be charged as provided in the City Code and/or Fee Ordinance and shall be updated periodically.

4.10.0 TESTING

A. Description

The Permittee shall material testing for each phase of the work at no cost to the City.

B. Laboratory and Technician Qualification Requirements

Laboratories shall have current accreditation by the American Association for Laboratory Accreditation (A2LA). Material tests shall be taken by technicians with current certification as follows.

1. Soil and aggregates: National Institute for Certification in Engineering technologies (NICET) Level 11
2. Portland Cement Concrete: (NICET) Level 11 or American Concrete Institute (ACI) Level 1
3. Asphalt Concrete: (NICET) Level II or Texas Department of Transportation TxDOT Level 1A (Plant Inspection), Level 1B (Field Inspection)

C. Frequency and Types of Tests

The following testing frequencies shall be followed. The number of tests required may be adjusted for large projects when different frequencies are provided in individual standard specification section if approved by the Director,

1. Minimum Horizontal Frequencies for Density Tests:
 - a. Utility Trench-One test per 100 linear feet per lift for each utility trench.
 - b. Utility Hole, Manhole, or Valve Box-One test per lift.
2. Construction Activities Tests:
 - a. Backfill-One test for every 2 vertical feet and 100 linear feet or fraction thereof, with at least one test per lift,
 - b. Cement Stabilized Sand-Testing as directed by Director.
 - c. Concrete Pavement, Curbs, Gutters, and Sidewalks - Four compressive test specimens per each 100 cubic yards or portion thereof.
 - d. Asphalt Concrete Pavement:
 1. Asphalt Content-One test per 500 tons or fraction thereof of mix produced with a minimum of one test per day's placement.
 2. Aggregate Gradation-One test per 500 tons or fraction thereof of mix produced with a minimum of one test per day's placement.
 3. In-Place Density-One test per 500 tons or fraction thereof of mix placed with minimum of one test per day's placement.

D. Base Course Materials: - One test per 400 lane feet with no fewer than two tests per Excavation.

E. City Inspection/Certificate of Completion

All construction work within the public rights-of-way shall be subject to inspection by the Director and/or third party inspection. It shall be the responsibility of the Permittee to provide safe access for the inspector to perform the required Inspections. Upon completion and receipt of affirmation on Inspection and successful execution of required tests, the City will issue a Certification of completion. Upon issuance of the Certificate, the warranty period provided in the Ordinance will commence.

END OF CHAPTER

Chapter 5

**STREET PAVING DESIGN
REQUIREMENTS**

STREET PAVING REQUIREMENTS

5.1.0 CHAPTER INCLUDES

Geometric design guidelines for streets, criteria for street paving and standard paving notes for drawings.

5.2.0 REFERENCES

- A. Refer to the list of references in Chapter 1, General Requirements.
- B. Texas Engineering Practices Act & Board Rules and Practices Procedure, latest revision.
- C. AASHTO – American Association of State Highway and Transportation Officials.
- D. ASTM – American Society for Testing and Materials.

5.3.0 DEFINITIONS

- A. Geotechnical Engineer – An engineer certified by the American Association for Laboratory Accreditation (A2LA)
- B. HMAC – Hot-Mix asphaltic concrete
- C. Curb-and-Gutter Sections – Full width concrete pavement with doweled on 6-inch curbs or monolithic curb-and-gutter sections for asphaltic concrete pavement. Curb-and-gutter sections require inlets and underground storm sewers.
- D. Roadside Ditch Sections – Ditch sections adjacent to either full width reinforced concrete pavement or asphaltic concrete pavement. Roadside ditch sections do not required underground storm sewers; however, the ditch sections must be designed to accommodate storm run-off.

5.4.0 DESIGN REQUIRMENTS

The following design requirements are applicable to pavements within City street rights-of-way:

- A. Width Requirements for Roadways: Geometric Design Guidelines for Subdivision Streets included with this Chapter for the Divided Roadway Cross Sections – Urban and Undivided Roadway Cross Sections – Urban.
- B. Minimum Thickness and Reinforcement Requirements for Concrete Pavement: The following requirements are the minimum allowable. Pavement thickness and reinforcement shall be designed by a Professional Engineer based on a current soils analysis, roadway use, traffic loadings, and life span of proposed pavement.
 - 1. For local Type A Streets with pavement widths less than or equal to 30 feet face-to-face (F/F) of curb:
 - a. Minimum concrete slab thickness shall be 6 inches (6") with $f_c' = 4,400$ psi and deformed steel bar reinforcement with $f_y = 60,000$ psi. Refer to Standard Details for reinforcement drawings. Place expansion joints at the end of each curb return and at a maximum spacing of 80 feet.
 - b. Minimum stabilized subgrade thickness shall be six inches (6").
 - 2. For Minor and Major Arterial Streets:
 - a. Minimum concrete slab thickness shall be eight inches (8") with $f_c' = 4,400$ psi and reinforcement with $f_y = 60,000$ psi. Refer to Standard Details for reinforcement drawings. Place expansion joints at the end of each curb return and at a maximum spacing of 80 feet.
 - b. Minimum stabilized subgrade thickness shall be six inches (6").
 - 3. For streets other than described in paragraphs 5.4.B.1 and 5.4.B.2 (i.e., streets greater than 30 feet F/F of curb and not major thoroughfares):
 - a. Minimum concrete slab thickness shall be seven inches (7") with $f_c' = 4,400$ psi and reinforcement with $f_y = 60,000$ psi. Refer to Standard Details for reinforcement drawings. Place expansion joints at the end of each curb return and at a maximum spacing of 80 feet.

- b. Minimum stabilized subgrade thickness shall be six inches (6").
- C. Minimum Thickness of Asphaltic Concrete Pavement: Minimum thickness of HMA surfacing and asphalt treated base shall be as determined by the pavement engineer.
- D. Subgrade Treatment: Treatment of subgrade shall be determined by a geotechnical engineer. The geotechnical engineer shall base depth of subgrade stabilization on structural number (SN) in conjunction with flexible pavement thickness design.
- E. Requirements for Intersections, Turnouts, and Transitions:
1. At a T-intersection with a street that has not been improved to its ultimate width, concrete pavement shall be stopped either at the right-of-way line or the end of the curb return, whichever would require less concrete removal at a future date.
 2. For roadway turnouts placed at an existing cross street intersection, the turnout should be designed to fit the ultimate pavement width of the intersecting cross street and then transitioned to the existing roadway.
 3. The usual transition length for meeting a roadside ditch street is 50 feet for street widths less than or equal to 30 feet F/F of curb; 75 feet for 42 feet F/F of curb; and 100 feet for 44 feet F/F of curb.
 - a. Transition sections for streets other than concrete shall consist of asphalt treated base paving. See Standard Specification 205 – Hot Mix Asphaltic Concrete Pavement Details.
 - b. Transitions for concrete streets shall consist of concrete and equal the existing pavement thickness with a minimum thickness of six inches (6"). See Standard Specification 209 Concrete Pavement Details.
 4. When meeting existing concrete streets at right angles, the existing street should be saw cut in a V-shape extending from the curb returns to a point where the centerline of the proposed pavement intersects the quarter point of the existing concrete street to create a crowned intersection. In the event this construction creates a situation in which traffic on the existing street, at design speed, will bottom out when crossing the proposed street intersection, a special design will be allowed to eliminate this potentially dangerous condition.
- F. Requirements for Roadway Ditches:
1. Ditch capacity shall be designed to handle storm water runoff in accordance with the Unified Development Code of City of Live Oak.
 2. Minimum ditch grades and maximum ditch side slopes shall conform to the requirements of the Unified Development Code of City of Live Oak.
 3. Culverts shall be designed to accommodate ditch flow and shall be constructed of reinforced concrete. Wall thickness shall be Wall B as given in ASTM C 76.
- G. Requirements for Roadways with Curb and Gutter Section.
1. Minimum grade line shall be 0.40 percent.
 2. Minimum grade line shall be one percent for radii of 35 feet or less around intersection turnouts. Grades for larger radii shall be determined on an individual basis.
 3. Vertical curves shall be installed when the algebraic difference in grades exceed one and a half percent. Elevations shall be shown at ten foot (20') intervals through vertical curves. Maintain a minimum of 0.30-foot elevation change at ten foot (10') intervals by altering calculated elevations.
 4. Radii around cul-de-sacs shall be 40 feet for local Type A and 50 feet for all others.
 5. When a curb-and-gutter street intersects a drainage ditch, the gutter elevation shall be above the designed water surface elevation of the ditch.
 6. Minimum grade line around a cul-de-sac shall be 0.70 percent.
 7. Major thoroughfares shall be super elevated in accordance with recommendation of AASHTO.

8. Cross slopes for pavement shall be as shown on Standard Details. The minimum cross slope for left-turn lanes and esplanade openings shall be 1/8 inch per foot.
9. Minimum grade line around the longest radius on a local Type A street shall be 0.40 percent.
10. When meeting an existing curb-and-gutter street, top-of-curb elevations shall be designed to meet an elevation seven inches (7") above the existing gutter. At existing inlets, top-of-curb elevations shall be designed to match existing top-of-curb elevations.
11. When the curb grades are not established below the natural ground, fill lines shall be shown on the drawings and shall be of sufficient height to ensure a minimum of 3/8 inch per foot transverse slope toward the curb from the property line between a point two feet (2') outside the right-of-way line and the top of curb. If this type fill is required and the pavement is adjacent to a nonparticipating property owner, fill easements shall be obtained, filed and a copy of the easements shall accompany the final drawings. Construction of this nature will require back-slope drainage design to prevent trapping storm runoff.
12. The maximum desirable tangent grade to vertical curves at railroad crossings is eight percent (8%) for local streets and three and a half percent (3.5%) for major thoroughfares.
13. Top-of-curb grades for the outside lanes shall be labeled except at railroad crossings where gutter grades shall be labeled. Centerline grades are acceptable for streets with roadside ditch sections.
14. Roadway grades at railroad crossings shall be zero percent (0%) from centerline of the track to 10 feet (10') either side of the track's centerline, and should not cause a drop of more than 6 inches (6") from the top-of-rail elevation at a distance of 30 feet either side of the track's centerline.
15. For concrete roadways, the roadway shall terminate at a railroad header, 6 feet (6') from the centerline of the track and the roadway cross slope shall be zero feet (0') from the railroad header to 4 feet (4') before the railroad header.

H. Requirements for Curbs, Sidewalks, and Driveways:

1. Standard curb height is 7 inches (7")
2. At railroad track approaches, decrease curbs from 7 inches (7") to zero inches (0") in two feet (2') at a distance of 10 feet (10') from the nearest track centerline.
3. Reinforced concrete sidewalks and driveways shall be in accordance with City Standard Details.
4. Reinforced concrete sidewalks in esplanades – Reinforced concrete sidewalks, six inches (6") thick, shall be constructed in esplanades when curbs are 10 feet F/F of curb and less in width with a minimum length of six feet (6') measured from the face of curb of the esplanade nose. Reinforced concrete sidewalks in esplanades shall be colored black for concrete roadways and uncolored for asphaltic concrete roadways.

I. Requirements for Thoroughfares:

1. When the full section of a thoroughfare is located within the city limits and is dedicated on a final plat, the esplanade and all lanes of the thoroughfare shall be constructed at the time of initial construction of the roadway.
2. If approved by the Director, lanes contained within a plat, left-run lanes and the esplanade to the center line of the right-of-way shall be constructed at the time of initial construction of the roadway when only one side of a thoroughfare is located on a final plat. The remaining lanes, left-turn lanes and esplanade shall be constructed at the time the final plat containing the opposite side of a half constructed thoroughfare is approved.

3. Permanent barricades, conforming to the requirements of the TMUTCD, shall be constructed at the termination of lanes on partially constructed thoroughfares. The barricades shall contain a sign reading FUTURE ROADWAY EXTENSION.

J. Requirements for Miscellaneous Items:

1. The type and depth of subgrade treatment shall be as determined by the geotechnical engineer.
2. For proposed driveways, call out centerline stations, widths, and radii.
3. Paving headers shall be placed at the end of concrete pavements.
4. Concrete to be removed shall be removed either to an existing joint or a sawed joint. The groove of the sawed joint shall be cut to a minimum depth of two inches (2") along the line designated by the Professional Engineer.
5. Determine minimum vertical curve lengths based on AASHTO design criteria (minimum 3 times design speed) using a minimum design speed of 45 miles per hour for thoroughfares and collector streets and 30 mph for residential streets.
6. Standard City barricades shall be placed at the end of dead-end streets not terminating in a cul-de-sac.
7. A letter of agreement between the City and pipeline company approving the construction plan crossing is required when paving a placed over a transmission pipeline.
8. When meeting existing concrete pavement, horizontal dowels shall be used if no exposed reinforcing steel exists. Horizontal dowels shall be Grade 50 bars, 24 inches long, drilled and embedded 12 inches into the center of the existing slab with PO ROC or approved equal. Dowels shall be 12 inches center-to-center, unless otherwise specified.
9. When concrete is removed for connection with proposed concrete pavement, the pavement shall be saw cut and existing concrete removed to expose a minimum of 15 inches of reinforcing steel. If no reinforcing steel exists, use horizontal dowels.
10. Adjust existing manhole frames and covers within the limits of the proposed pavement to meet the proposed top-of-slab or street elevation.
11. Adjust existing manhole frames and covers outside the limits of the pavement to conform to the final grading plan.

5.5.0 QUALITY ASSURANCE

- A. Final design drawings and specifications shall be prepared by or under the supervision of a Professional Engineer, and all documents shall be sealed, dated and signed by the responsible Professional Engineer, based on the Texas Engineering Practices Act & Board Rules and Practices Procedure, latest revision, and all other State and Federal Laws.
- B. Geotechnical work shall be performed by or under the supervision of a Professional Engineer. All reports and documents shall be sealed, dated and signed by the responsible Geotechnical Professional Engineer, based on the Texas Engineering Practices Act & Board Rules and Practices Procedure, latest revision, and all other State and Federal Laws.

5.6.0 DESIGN ANALYSIS

- A. Pavement thickness and reinforcement shall be designed by a Professional Engineer based on a current soils analysis, roadway use, traffic loadings, and the life span of proposed pavement.
- B. The number and location of storm sewer inlets shall be designed to accommodate storm water runoff. A graphical plot and calculations of the hydraulic gradient shall be furnished by the design engineer. The hydraulic gradient shall be in accordance with the Unified Development Code of the City of Live Oak.

- C. Roadside ditch drainage and culverts shall be designed in accordance with the Unified Development Code of the City of Live Oak.

5.7.0 STANDARD PAVING NOTES FOR DRAWING CALL OUTS

- A. The following notes or phrase are specific to paving improvements and should be included in final design drawings containing paving improvements. The plan-and-profile sheets should reference the notes or phrase in the plan view by note number as listed below.

Paving Notes:

1. Proposed asphalt treated base as shown on Standard Specification 206 – Hot Mix Asphaltic Concrete Pavement Details.
2. Proposed sawed joint and expose 15-inches of reinforcing steel. If no reinforcing steel exists, use horizontal dowels. See Note 10.
3. Proposed esplanade curb.
4. Proposed standard monolithic curb and gutter as shown on Standard Specification 500 Concrete Curb, Gutter and Concrete Curb and Gutter.
5. Dowel on six inch (6") curb after asphaltic surfacing is in place, or into existing concrete pavement, as applicable.
6. Rack over existing manhole to miss proposed curb, if conflict exists. Maximum rack of one-inch (1") per course of brick.
7. Remove and replace sidewalk as directed by the Engineer.
8. Proposed $\frac{3}{4}$ inch board expansion or pre-molded non-extruding joint between walk and curb.
9. Remove a sufficient length of concrete pipe, as determined by the Engineer, and connect to proposed inlet with reinforced concrete pipe of like diameter.
10. Horizontal dowels shall be No. 6 bars, 24 inches long, drilled and embedded 12 inches into the center of the existing slab with PO ROC or equal. Dowels shall be 12 inches, center to center, unless otherwise specified.
11. The contractor shall notify the City Public Works Department, ten (10) working days in advance for relocation of existing traffic signal poles.
12. Adjust existing inlet to fit new grade and alignment.
13. Decrease curb exposure from seven inches (7") to two inches (2") in one foot (1')
14. Decrease curb exposure from seven inches (7") to two inches (2") in four feet (4')
15. Decrease curb exposure from seven inches (7") to zero inches (0") in two feet (2')
16. Proposed reinforced concrete sidewalks shall be colored black for concrete roadways and uncolored for asphaltic concrete roadways.
17. Rip-Rap shall be placed on slopes and ditches as directed by the Engineer.
18. Covert existing inlet or manhole with inlet top to manhole.
19. Remove existing culvert
20. Remove and replace pipe culvert as directed by the Engineer.
21. Existing structure to be removed.
22. Break into barrel of monolithic reinforced concrete storm sewer. Cost to be included in the unit price bid for storm sewer or lead, as applicable.
23. Proposed doweled-on, 12-inch-wide mountable curb.
24. Shaded area denotes approximate limits of proposed asphalt overlay.
25. Remove existing inlet. Plug and abandon lead.
26. Remove existing concrete pavement, concrete base, and cement stabilized shell base course with or without asphalt surfacing.
27. Proposed asphalt overlay.
28. Remove inlet and extend lead.
29. Meet existing curb or curb and gutter for grade and alignment.

30. Proposed wheelchair ramp, as shown on Standard Specification-Wheelchair Ramp Details.
 31. Adjust existing manhole frame and cover to fit new grade.
 32. Remove curb or curb and gutter, as applicable.
 33. Adjust existing water valve boxes to new paving grade. Replace missing or damaged valve boxes and covers.
 34. Replace Type B inlet with Type BB inlet or Type C-1 inlet.
 35. Remove mountable curb.
 36. Proposed pavement markings as shown on Standard Specifications-01-Pavement Marking Details.
 37. Proposed white plastic marker as shown on Traffic and Transportation Drawing, Standard Elongated Word and Arrow Symbol Design Details for Pavement Markings.
 38. Proposed plastic marker, as shown on Traffic and Transportation Drawing, Standard for Left Turn Channelization.
 39. Proposed standard concrete paving header as shown on Standard Specifications-Curb, Curb and Gutter and Header Details.
- B. The following notes or phases are specific to Asphalt Overlay Improvements and should be included in final design drawings containing Asphalt Overlay Provisions:
1. The Contractor shall be responsible for determining the existence, depth, and location of all utilities. The Contractor shall also be responsible for any damage to and for the maintenance and protection of the existing utilities even though they may not be shown on the plans. Any damage that might occur shall be repaired at the Contractor's expense.
 2. Due to Federal Regulations Title 49, Part 192.181, CPS must maintain access to gas valves at all times. The Contractor must protect and work around all gas valves that are in the project area.
 3. Contractor to protect and support telephone company plant during construction.
 4. Call Texas Excavation Safety System (TESS) at 811 for the utility locators and the City of Live Oak Utilities for the various utilities that may be encountered
 5. Concerning utility adjustments which are to be performed by others, minimum of ten (10) days notice shall be given by the Contractor to the concerned utilities prior to seal coating so that the necessary adjustments can be made.
 6. All existing raised pavement markings shall be removed by the Contractor daily as the work progresses and as approved by the Engineer. This work will not be paid for separately but shall be considered subsidiary to the various bid items. Materials removed shall become the property of the Contractor.
 7. All waste materials shall become the property of the Contractor and it shall be their sole responsibility to dispose of these materials off the limits of the right-of-way and on private property where the Contractor has the consent of the owners. No waste material shall be placed in designated FEMA flood plains or in low areas that will block or alter the flow of existing natural drainage.
 8. The Contractor shall be responsible for restoring to its original or better condition any damages done to existing fences, buildings, driveways, sidewalks, curbs or other structures.
 9. Actual "Base and Pavement Replacement", "H.M.A.C.P., Type D, (Level-Up)", and temporary paint traffic markings quantities may be varied by the Engineer.
 10. Payment for all Level-Up courses shall be made under Item No. 205G.

Placement of Level-Up asphaltic materials shall be performed by a motor grader. Allowable Level-Up materials shall be Hot Mix/Hot Laid Asphaltic Pavement Type "G" as specified in Item 205. The locations and depths of Level-Up shall be as directed by the Engineer.

11. Building paper shall be placed over all manholes, valve boxes, grates, etc., so as to protect the surfaces from asphaltic materials and shall otherwise remain visible and accessible throughout the duration of the project. Asphaltic materials shall not be placed, lapped, or splashed onto adjacent structures.
12. All asphalt cuttings and aggregate materials shall be confined to the street surface where they shall be swept up and removed by the end of each workday.
13. All materials, such as asphalt cuttings and Seal Coat aggregate, not used by the end of each work day must be stored at locations other than the street surface.
14. Repaired Base Failures shall cure-out for a minimum of 15 days prior to it being Seal Coated.
15. Base and pavement failures located between existing railroad tracks shall be carefully removed up to the top of the railroad ties and replaced with new materials as per detail. Any damage to Railroad system due to work performed by the Contractor shall be repaired by the Contractor at his own expense. (Pay Item No. 257)
16. Pavement cuts shall be as performed by approved equipment and shall not remain in such a state whereby the cut presents a hazard to traffic.
17. All daily base and pavement failure replacements shall be properly excavated, barricaded, and open to traffic the same day.
18. Asphalt Treated Base and pavement mixtures shall be at a temperature between 225°F and 350°F when placed in excavated cuts. When the asphalt temperatures fall below 225°F, the asphalt must be discarded and payment will not be made for the discarded material.
19. Street surfaces adjacent to manholes, water valves, drain grates, bridge joints, curbs, etc., shall be completely milled to the depth as specified for the street unless otherwise directed.
20. Typically, milling of asphaltic pavement shall be performed within turnouts which are adjacent to streets which have been identified in the plans to be milled.
21. Should existing base materials become exposed due to milling, the Contractor shall protect and maintain the existing compacted base until which time it can be overlaid. Exposed flexible bases shall be rolled and primed coated as directed by the Engineer.
22. Actual depths of milling along curb lines and on bridge decks shall be as directed. Concrete bridge decks shall not be milled.
23. Prior to the application of Seal Coat, all manholes shall be adjusted so that the ring and cover are flush with the finished grade of the new pavement. A single payment at the Contractor's unit bid price shall be made for each manhole adjusted to the finished grade of new pavement. Due to occasional varying depths of new pavement placement, repeated adjustments may become necessary to match the new finished grade.
24. Each street shall be Seal Coated in its entirety, including adjacent turnouts, prior to sealing other streets within the project unless directed otherwise.
25. All aggregate for Seal Coat shall be delivered to the job site at atmospheric temperature. Aggregate shall be adequately dried to the satisfaction of the Engineer prior to its usage in the Seal Coat.

Seal Coat material data:

Asphalt - Type / Grade Binder Oil: CRS - 2P

- | | |
|--------------------------|--------------------------------------|
| | Precoat Oil: MS-1 or CSS-1 |
| Asphalt – Rate | 0.28 - 0.32 gal./SY |
| Aggregate - Type / Grade | Precoated crushed limestone, grade 4 |
| Aggregate - Rate | 18 - 20 lbs./SY |
26. It is the intent that an asphalt cement binder oil be used for all Seal Coating, however if weather conditions are not conducive for its application, then an emulsion may be used at no extra pay.
 27. Within a given day, the Contractor shall not plane mill or overlay a street beyond the longitudinal limits of which he cannot mill or overlay for its full width unless directed otherwise by the Engineer.
 28. The percent wear of the Seal Coat aggregate material, as determined by Test Method Tex-410-A, shall not exceed 25%.
 29. Contractor shall maintain Seal Coat.
 30. Overlaying of street surfaces may commence the following day after which an acceptable application of seal coat has been applied as determined by the Engineer.
 31. It is the intent that Hot Mix Asphaltic Pavement, Type "C" shall be applied at a rate of 165 lbs/SY for overlaying purposes; however, the actual application rate may be greater where directed by the Engineer.
 32. Coarse aggregate material used for "H.M.A.P., (friction surface)" shall be composed of 30% by weight of crushed Trap Rock or crushed gravel. The percent wear of such material, as determined by Test Method Tex-410-A, shall not exceed 25%.
 33. All concrete surfaces and construction joints, which will contact the proposed the "H.M.A.C.P." overlayment shall be painted with a thin uniform coat of RC-250, used for tack coat. Tack coat shall meet the requirements of Item 203 and shall be at no direct pay.

C. TRAFFIC NOTES AND SPECIAL CONDITIONS

The following notes or phrases are specific to all work affecting the motoring public.

1. It is the Contractor's sole responsibility to see that all traffic control devices are properly installed and maintained at the job site in accordance with the plans, specifications and related industry standards and regulations. The Contractor shall submit for review a sign and barricade plan conforming to the requirements of the TMUTCD. The City's construction observer/inspector (COI) and the traffic engineering representative will only be responsible to inspect the traffic control devices being deployed. If in the opinion of the traffic engineering representative and the COI, the traffic control devices do not conform to established standards or are incorrectly placed or are insufficient in quantity to protect the general public, the COI shall have the option to stop construction operations at no expense to the City until such time as the conditions are corrected by the Contractor.
2. Seventy-two hours prior to removing any traffic signs or traffic signals, the Contractor shall contact the City of Live Oak Traffic Operations Division at 653-9140. Prior to completion of the contract and removal of the barricades, the Contractor shall again contact the Traffic Operations section. The barricades shall not be removed until all applicable permanent traffic signs and signals are in place.
3. It is the Contractor's responsibility to obtain and maintain temporary stop signs and all other traffic control devices required to protect the general public. If the City of Live Oak has removed permanent stop signs, the Contractor shall request that the signs be returned to the construction site to be reinstalled by the Contractor. All Permanent signs or traffic control devices missing or damaged upon completion of construction shall be replaced at the contractor's expense.

4. The Contractor must contact the City's COI forty-eight (48) hours in advance (not including weekends) of any minor street closure. It will be the Contractor's responsibility to advise the COI ten (10) days in advance of an arterial total street closure. This much time is necessary to install advisory signs and give the motorists a minimum of seven (7) days notice of the street closure. The COI after being notified will contact the traffic engineering office to make the necessary arrangements.
5. As work progresses, location of temporary traffic control devices will be adjusted and modified, as necessary the Contractor at the Contractor's expense.
6. If the need arises, additional temporary traffic control devices, special directional devices, and/or business name signs may be ordered by the traffic engineering representative at the Contractor's expense.
7. Temporary traffic control devices shall conform to the City's "Typical Sign and Barricade Standards" sheets and to the TMUTCD.
8. The Contractor is responsible for repairing all streets outside of the project limits which were damaged by construction activities. The replacing section must be approved by the City's Director of Public Works. There will be no direct payment for this work.
9. The Contractor shall be responsible for providing suitable access accommodations for school children and pedestrians.
10. The Contractor shall provide access for delivery of mail by the U.S. Postal Service.
11. The Contractor shall provide for access to residences and all businesses at all times within all the phases of the work.
12. When construction work necessitates the utilization of vehicle paths other than the lanes normally used, traffic control markings no longer applicable shall be removed and approved temporary pavement markings and signs installed in accordance with Part VI-D of the TMUTCD. After construction is completed and traffic is rerouted back to the original lanes, the traffic control markings and/or raised buttons that were originally removed from the existing pavement must be replaced. In addition, temporary markings must be removed.
13. All temporary traffic control devices, etc. shall be provided by the Contractor without direct cost to the City of Live Oak, unless otherwise noted or stated.
14. Any damage to permanent traffic signals, the controller box, loops or conduits during or upon completion of the project shall be repaired or replaced at the Contractor's expense. The decision to repair, as opposed to replace, the damaged equipment shall be made by the City's Director of Public Works. The Contractor is responsible for repairing all streets outside of the project limits which were damaged by construction activities. The replacing section must be approved by the City's Director of Public Works. There will be no direct payment for this work. The cost is to be included in other items. Off-duty police officers will be required as directed by the Traffic Engineer at no direct payment, cost to be included in other Bid Items. This will be a requirement when working in or adjacent to a signalized intersection and where two-way traffic is to be maintained.
15. The Contractor shall provide the City and emergency telephone number for evenings, weekends, and holidays by the first working day of the project. This telephone number must be a commercial answering service. The answering service must be able to contact the Contractor and the Contractor respond back to the City staff within two hours of the initial contact.
16. Locations and layout of Detector Loop Replacements shall be verified by the City Engineer prior to their removal and installation.

17. It shall be the Contractor's responsibility to notify all residents and businesses adjacent to the project of construction operations and schedules. The City shall provide all printed notification material to the Contractor for his distribution to the affected citizens and businesses.
18. The Contractor has the responsibility for posting and removing all temporary "no parking signs", which are to be provided by the City, at all work sites as directed.
19. After utilities have made their required manhole and valve adjustments, it shall be the Contractor's responsibility to properly barricade and maintain the barricades to ensure that the public is safeguarded while traveling within the construction area. The Contractor shall contact the Traffic Engineer for a review of the adequacy of the barricades. There shall be no separate payment for this item.
20. The barricade company shall supply the Contractor with a sufficient number of quality standard barricades and other traffic control devices by TMUTCD standards as needed. The barricade company shall also supply the Contractor with two (2) full-time qualified personnel whose sole responsibilities pertaining to this project are to establish and maintain proper construction work zone traffic control and related devices. These persons shall provide documented evidence that they have received specialized training in construction work zone traffic control within two years on the contract date. Any and all traffic control devices needed and necessary personnel will be at the Contractor's expense.
21. For streets which accommodate four (4) or more traffic lanes, the following restrictions will apply:
 - a. Two-way traffic shall be maintained.
 - b. A minimum of two lanes shall remain open for traffic.
 - c. No more than 1,000 linear feet of a roadway lane may be closed during construction operations.
 - d. A minimum of one (1) off-duty Police Officer shall be required on site during base failure repair, seal coating, milling, and H.M.A.C.P. overlay operations.
 - e. Work may be performed on weekends with prior approval from the Director.
 - f. When performing work operations at night, the contractor shall provide adequate lighting to perform the necessary operations. In addition, all vehicles must be equipped with one or more high intensity yellow flashing lights.
 - g. Flashing warning lights and/or flags shall be used to call attention to all advance warning signs.
 - h. Signs which read "FRESH OIL" shall be placed at each end of work areas and at all turnouts adjacent to work areas where Seal Coating is being performed until such time that the Engineer gives permission for their removal.
 - i. Signs which read "CONSTRUCTION AHEAD. TRAFFIC DELAYS TO BE EXPECTED" shall be placed at each end of work areas. Said signs shall be 60" x 30" and shall be orange with black lettering.
22. All traffic markings shall be placed in accordance with the City's Traffic Engineer. He shall be given a minimum of forty-eight (48) hours notice prior to the application of any markings.
23. All streets, for their full width, shall be open to traffic at the end of each work period.
24. Approved temporary short-term expendable pavement markings shall be provided to delineate lane continuity prior to the application of standard markings by the use of flexible-reflective road marker tabs. Once the existing

standard pavement markings have been obliterated, such tabs shall remain in place for a maximum of fourteen (14) days after which time standard thermoplastic pavement markings must be applied. At the Contractor's option, the Contractor may apply standard painted markings prior to the application of the thermoplastic markings for an interim period of time.

25. Subsequent to an initial application of standard painted markings, repeated applications of such may become necessary until standard thermoplastic traffic markings are in place. As a function of the marking's effective visibility, the Director will determine when re-application of the painted markings are necessary. Painted markings shall be applied to delineate full centerlines and lane lines and will require glass beads.
26. Standard thermoplastic traffic markings are to be placed in no less than 2 days from a successfully completed H.M.A.C.P. application.
27. Contractor to contact the City's Traffic Engineering office at 207-7758 48 hours prior to sidewalk and curb construction where City owned traffic facilities exist. Contractor shall secure approval from Engineer prior to such construction. No wire splices shall be made outside the pull box. If wires should be cut outside the pull box by the Contractor, said Contractor shall then replace the entire wire.

END OF CHAPTER

Chapter 6

SURVEY REQUIREMENTS

SURVEY REQUIREMENTS

6.1.0 CHAPTER INCLUDES

Suggested guidelines for use by engineers in development of construction drawings and right-of-way maps inside the Live Oak City limits. These guidelines are required for City of Live Oak Capital Improvement Projects and Utility Capital Improvement Projects.

6.2.0 REFERENCES

- A. Professional Land Surveying Practices Act, latest revision.

6.3.0 DEFINITIONS

Surveying work must be in accordance with the rules and regulations of the Texas Board of Professional Land and Surveying (TBPLS) Practices Act and General Rules of Procedures and Practices. Surveyor work must be done under the supervision of a registered Professional Land Surveyor in the state of Texas.

6.4.0 SUBMITTALS

- A. For work performed through an engineering service contract with the City, deliver field books and an electronic file in standard ASCII format (Point Number, Northing, Easting, Elevation, Description). Photocopies or carbon copies of field books are not acceptable. Field books and electronic files will be retained in the City's permanent files.
- B. For right-of-way drawings identifying or describing acquisition of new or additional rights-of-way, deliver field books and database printout files to the City Surveyor or a designee of the City Surveyor. Additional documents to be submitted are:
 - 1. Overall map of rights-of-way with individual drawings of parcels identified on overall maps. Map or drawing media shall be mylar.
 - 2. Computer printouts of coordinate computations.
 - 3. Abstract information and copies of instruments used (i.e., deed) in preparation of the right-of-way.

6.5.0 QUALITY ASSURANCE

- A. Field surveying used in the development of construction drawings, calculations and preparation of right-of-way maps, and field note descriptions shall be performed by or under the direct supervision of a Professional Surveyor.
- B. Surveys shall comply with the latest revision of the Professional Land Surveying Practice Act of the State of Texas
- C. Field notes, descriptions and right-of-way maps shall have the imprinted or embossed seal of the responsible Professional Surveyor and shall be dated and signed by the Professional Surveyor.
- D. All Surveyors, when establishing horizontal control, shall transcribe onto the pages of a standard Survey Field Book, as described in paragraph 6.3, all angles and distances, at the time of measurement, with an accompanying sketch. When establishing vertical control, the surveyor shall use differential leveling methods, and transcribe the vertical data onto the pages of said standard Survey Field Book, with an accompanying sketch.

6.6.0 FIELD WORK

- A. For engineering contracts with the City, field work shall be recorded in field books or on total station database printouts. Obtain a field book number from the Survey Section or Director and record this identification in the title block on drawing sheets.
- B. The control line must be monumented at its beginning, end, and at angle points with markers of a permanent nature, such as iron rods, spikes or other lasting identification. Make reference drawings for each control monument showing ties to planimetric features to allow easy recovery. Set markers at a maximum of 1000 feet

- on long lines.
- C. Make ties of the found right-of-way monuments and property corners to the control line.
 - D. Use City datum for elevations when available. Set temporary bench marks (TBM) within 200 feet of the beginning and end of the project and at intervals not to exceed 1000 feet throughout the project.
 - E. Show centerlines and angles of intersections of side streets with the main roadway centerline station.
 - F. Record topographic features within the public right-of-way, proposed right-of-way, any contiguous easements to the right-of-way, and any construction right-of-way of the project and on intersecting streets for a distance of 20 feet beyond the intersection of the right-of-way lines. Identify all visible underground structures, such as inlets, manholes and junction boxes, with size, depth and type.
 - G. Cross sections shall be taken at intervals of 100 feet. For levels recorded in field books, record rod reading or elevations as numerator and distance right or left on the base or centerline as the denominator. Data collector of a total station can be used to acquire necessary elevations at required intervals. Record elevation of driveways at intersection of driveway centerline with existing or proposed right-of-way line.
 - H. For acquisition of new or additional rights-of-way:
 - 1. Tie points of commencing (POCs) or points of beginning (POBs) for each parcel to the City survey monuments, if within 2000 feet of the parcel. In the event any on parcel in the right-of-way is within 2000 feet of a City monument, tie all parcels to the monument.
 - 2. For projects more than 2000 feet from a City survey monument, job coordinates will be permitted with the origin of coordinates shown and monumented on the map. The assumed coordinate system must leave no question as having any relationship to true "x", "y" using the Texas State Plane Nad 83Coordinate System.
 - 3. Set ½ inch x 18 inch iron rods or permanent markers at the intersections of the proposed right-of-way and property lines of parcels to be acquired.
 - 4. Identify monuments, corners, angle points, points of curve (PCs), point of intersection (PIs), points of tangency (PTs), and other points as either "found" or "set". Describe each point such as ½ inch iron rod, ¾ inch iron pipe, axle, concrete marker, disk, or other item.
 - 5. Locate improvements, buildings, fences, permanent signs, and other structures within the parcel or within 10 feet of the proposed right-of-way that will influence the value of the parcel to be acquired.

6.7.0 CALCULATIONS

- A. Calculate coordinates of proposed right-of-way parcels, control points, found or set monuments, curve data, lengths, stations and offsets to monuments, and proposed improvement features. Calculate areas, cross sections and volumes associated with construction drawings.
- B. Computer printouts of the coordinate calculations should be submitted to the City with field books and database printout files.

6.8.0 CONSTRUCTION DRAWINGS

- A. Found existing right-of-way monuments or property corners must be plainly shown on the drawings and located by station and distance, right or left from the control line, or construction centerline. Monuments used to establish the control line must be identified as Control Points, and their relationship to the construction centerline and to the proposed or existing right-of-way lines must be shown. If the project is dimensioned from a control line, such as construction or design baseline, which is different than the control line referenced in paragraph 6.7.0, it must be established and monumented in accordance with the requirements of paragraph 6.7.0.

- Coordinates for transverse control points and all points of curve, points of tangency and point of intersection along the design baseline shall be shown.
- B. Project should include three or four Primary Control points, which are established at stable monuments outside of the project area. Secondary control points are located within the project area and are susceptible to disturbance due to construction activities.
 - C. Show location and identification of existing City survey monuments, right-of-way monuments, and found property corners by station and distance, right or left of control line or centerline. Show swing ties set for control or centerline control.
 - D. Show and identify location of the City datum monuments and temporary bench marks used for elevation control with year of the City datum on each sheet of the drawings. List the TBM located closest to that particular sheet in a station/offset, description and elevation format.
 - E. Show centerline angles of intersection of side streets with main roadway centerline. Where bearings are used, identify source of bearings and show bearings on both control line and project centerline when they are not the same line.
 - F. Identify locations of manholes, angle points, ends, etc. for proposed wastewater, storm sewers, water lines and pavement features such as radius returns and centerlines of boulevard openings, show relationship of proposed improvements to the right-of-way.
 - G. For bridges, overpasses and underpasses, show top of pavement elevations at gutter line and centerline for the following locations:
 - 1. Construction joints
 - 2. Armor or expansion joints
 - 3. Intervals between bents that correspond to the increments used for dead load deflection calculations.
 - H. For bridges and grade separations, drawings must incorporate layout sheets which identify proposed centerline and curve information plus:
 - 1. Surface coordinates for control points so that an inverse between coordinates reflects a surface distance. Identify origin of coordinate system used.
 - 2. Show coordinates of centerline or control line at PIs.
 - 3. Show coordinates of curb lines at their intersection with the centerline of bents and abutments for irregular structures.

6.9.0 RIGHTS-OF-WAY

- A. Show true "x," "y" values (i.e., grid) on monuments based on the City survey control and the scale factor used to determine the "x" and "y" values. Distances shown shall be surface distances and plainly marked as such. Show ties to the POC or POB of each right-of-way parcel from the City survey monuments using the Texas Plain Coordinate System bearings and surface distances.
- B. Surveyors may use assumed coordinates on any project that is located more than 2000 feet from any existing City of Live Oak monument. Show location of monuments used as origin of job coordinates. The assumed coordinate values must leave no question as to their relationship with true "x," "y" using the Texas State Plain NAD 83 Coordinate System.
- C. Distances on proposed right-of-way lines shall be continuous from beginning to end of the job. Show either straight line or arc distance across intersecting streets.
- D. Where a parcel is taken from a larger tract, show dimensions, distances, and area of the remainder of the tract based on recorded information.
- E. Identify the evidence used to decide the final placement or establishment of the proposed right-of-way line, such as angle points, or corner monuments, as either "set" or "found." The description of each point used shall be shown on the drawing as identified in the field survey.
- F. Coordinate values of "x," "y" shall be shown for PCs, PTs, and PIs of curves on the proposed right-of-way lines. Curve data must include the following: delta, radius, arc

- length, chord length, and chord bearing.
- G. Coordinate values of “x,” “y” must be given on the POB of at least one tract in each block. Where the proposed right-of-way is to be acquired from a large tract of land, coordinate values should be given for the POB of field note description of the large tract.
 - H. Other information to be shown on right-of-way maps:
 - 1. Improvements such buildings, fences, permanent signs, and other structures located on the property or within 10 feet outside the right-of-way line that will influence the value of the parcel to be acquired.
 - 2. Abstract information used in preparation of the right-of-way map.

6.10.0 DOCUMENTS

- A. Where new construction will damage, destroy, or alter existing survey markers, include in specifications a requirement for installation of survey marker boxes by construction contractor at a unit price per box. The Director will determine the number and location of boxes to be furnished and installed by the contractor.
- B. Maps and metes and bounds field notes shall have the Professional Surveyor’s seal imprinted or embossed on them and shall have the Professional Surveyor’s signature and date affixed to the instrument.

END OF CHAPTER

CHAPTER 7

GEO TECHNICAL REQUIREMENTS

GEOTECHNICAL REQUIREMENTS

7.1.0 INTRODUCTION

This chapter includes minimum geotechnical investigation requirements for design of utilities with a trench depth of five feet (5') or more; utility facility greater than twenty inches (20") in diameter and all Street or Alley Paving Projects. Utilities include water lines, wastewater systems, and storm water drainage conduits and open channels. Streets include design of street pavements. This chapter is not intended to address tunnel projects.

7.2.0 REFERENCES

- A. AASHTO– American Association of State Highway and Transportation Officials.
- B. AREA – American Railroad Engineering Association.
- C. ASTM – American Society for Testing and Materials.
- D. OSHA – Occupational Safety and Health Administration.
- E. TxDOT – Texas Department of Transportation, Foundation Exploration and Design Manual.
- F. TCEQ – Texas Commission on Environmental Quality

7.3.0 INVESTIGATION REQUIREMENTS

- A. A geotechnical investigation is required prior to design under the conditions listed below. Data from earlier project design activities can be incorporated if sufficient and reliable for the current project. A geotechnical investigation by borings is required for design of:
 - 1. Underground utilities using open cut methods.
 - 2. Underground utilities to be augured beneath existing streets, pipelines, or other obstructions or structures.
 - 3. Street paving.
 - 4. Construction which could affect the integrity of adjacent structures, with the exception of utilities at a depth less than five feet (5'), interconnections such as service connections, and meter vault installations.
- B. Install piezometer(s) in a water-bearing layer.
 - 1. Read water levels 24-hours after initial installation and at 30 days just prior to removal and grouting.
 - 2. Space piezometers no greater than 2500 feet apart.
- C. The minimum geotechnical recommendations shall consist of the following:
 - 1. Open-cut Trenches: Bedding, backfill, excavation wall and bottom stability, thrust restraint, ground water control requirements at boring locations, dewatering method, and flexible pipe design parameters.
 - 2. Auger Installation: Soil design parameters, ground stability, augur pit excavation stability, dewatering recommendation.
 - 3. Appurtenance: Bearing capacity, lateral earth pressures, excavation stability, dewatering.
 - 4. Open Channel: Slope angle or slope ratio, setback distance, and erosion protection.
- D. All projects requiring a geotechnical investigation shall have a reconnaissance fault study to determine the potential for known active faults to impact the project. If the project is part of a larger tract for which a reconnaissance fault study is available, the results of the study on the larger tract will satisfy this requirement.
- E. For privately funded subdivision development in the City or subdivision development in a utility district, when borings have been conducted for a master study of the development and development of an adjacent section has been conducted, subsequent design within sections of the master planned area may not required individual borings or a geotechnical report. The borings and report may not be needed if the project design provides for field verification of encountered condition by direct supervision of a registered geotechnical engineer and provides for response to

unexpected soil conditions encountered during construction and those responses are in accordance with City design standards.

7.4.0 INVESTIGATION OF GRANULAR AND COHESIVE SOILS

- A. A bore-hole sampling and testing procedure shall include obtaining undisturbed Shelby Tube samples in cohesive soils and Standard Penetration Test Split-Barrell samples in granular soils, if not otherwise required (see paragraph 7.5.0). Continuous sampling shall be performed to a minimum depth of ten feet (10'), and at five-foot (5') intervals below that depth. Additional samples shall be obtained at strata changes encountered within the standard five-foot (5') sampling intervals.

7.5.0 INVESTIGATION CRITERIA

- A. Utility Line Projects. The frequency and depth of borings for utility line project shall not be less than described below unless waived by the Director. Bore an additional 5 feet if the last planned sample is in water-bearing sand. Make borings within an offset distance of no more than 20 feet from the centerline alignment of the utility line or at the location of the proposed structure. Soil borings shall be made at a spacing not greater than 500 feet with additional boring at closer spacing to better define areas of inconsistent stratigraphy.
 - 1. Open-cut Construction and Auger Pits:

Table 7.1.1
REQUIREMENTS FOR BORING DEPTHS

TRENCH WIDTH	TRENCH DEPTH	BORING DEPTH
Up to 6 feet	All	Trench Depth + 5 feet
Greater than 6 feet and up to 10 feet	Up to 10 feet	Trench Depth + 5 feet
Greater than 6 feet and up to 10 feet	10 to 15 feet	Trench Depth + 10 feet
Greater than 6 feet and up to 10 feet	Greater than 15 feet	Trench Depth + 1.5 times trench width
Greater than 10 feet	All	Trench Depth + 1.5 times trench width

- 2. Augured Sections: Make boring depth to line depth plus five feet (5') for lines up to ten feet (10') deep. For lines over ten feet (10') deep, make boring depth to line depth plus ten feet (10').
- B. Water Line Projects
 - 1. The frequency and depth of borings for water line projects shall conform to those listed in paragraph 7.5.0.A, Utility Line Projects.
 - 2. A geotechnical investigation is required for any waterline with nominal bedding depth greater than five feet (5') or water line diameter greater than 20 inches.
- C. Wastewater Line Projects
 - 1. The frequency and depth of borings for wastewater line projects shall conform to those listed in paragraph 7.5.0.A, Utility Line Projects.
 - 2. In addition, at least one boring must be made within 20 feet of the proposed center of a lift station. For lift stations 30 feet in diameter or larger, make one boring at the center; add borings around the periphery at maximum 50 feet spacing.
 - a. For City projects, the boring shall extend to:
 - (1) A depth of B below the bottom of the lift station, or

(2) A depth of 0.75 "D" below the bottom of the lift station, whichever is greater,

Where: "B" is the width or diameter of the lift station, and
"D" is the depth of the lift station or excavation

- b. For projects within the City's extra territorial jurisdiction (ETJ), the boring shall be to a minimum depth of ten feet (10') below the base of the structure.
 3. For City projects, install a piezometer within 20 feet of the center of the lift station. Read the water level again at 30 days after initial installation, then remove the piezometer and grout the hole.
 4. Other structures: A boring program shall be established by the owner and structural engineer in consultation with the geotechnical engineer.
- D. Storm Drainage, Box Culverts and Open Channels
1. The frequency and depth of borings for storm drainage pipes and box culverts shall conform to those listed in paragraph 7.5.0A, Utility Line Projects.
 2. Open Channels
 - a. Soil borings shall be made at a spacing not greater than 500 feet with additional boring at closer spacing to better define areas of inconsistent stratigraphy.
 - b. Channel depth (d) less than or equal to ten feet (10'), extend boring D feet below the ditch bottom.
 - c. For channel depth greater than ten feet (10') and less than or equal to 20 feet, extend boring ten feet (10') below the ditch bottom.
 - d. For channel depth greater than 20 feet establish boring depth to provide sufficient geotechnical information for design.
 3. Soils information for culverts in roadside ditches shall be obtained from soil borings made for the paving design, as described in paragraph 7.5.0E, Street Paving.
- E. Street Paving
1. Soil borings shall be made at a spacing not greater than 500 feet.
 2. The depth of borings shall be at least five feet (5') below the top of the curb for curb-and-gutter sections and five feet (5') below the crown of the road for open ditch sections, or three feet (3') below ditch invert, whichever is greater.
 3. Rigid Paving
 - a. The minimum geotechnical recommendations shall consist of the following: Pavement thickness, including minimum reinforcing and minimum subgrade treatment, as required in Chapter 10, Street Paving Design Requirements.
 4. Flexible Paving
 - a. Design Structural Number (SN), pavement thickness, subgrade treatment, as required in Chapter 5, Street Paving Design Requirement.
 5. Rehabilitation – rehabilitation recommendations.

7.6.0 LABORATORY TESTING PROGRAM

- A. Laboratory Tests may include but not be limited to the following:
1. ASTM D 4318 - Liquid Limit, Plastic Limits and Plasticity Index of Soils
 2. ASTM D 1140 - Amount of Material in Soils Finer than the No. 200 Sieve.
 3. ASTM D 2216 - Laboratory Determination of Water Content of Soil, Rock and Soil-Aggregate Mixture.
 4. ASTM D 422 - Particle Size Analysis of Soils
 5. ASTM D 2487 - Classification of Soils for Engineering Purposes.
 6. ASTM D 2166 - Unconfined Compressive Strength of Cohesive Soils.
 7. ASTM D 2850 – Unconsolidated-Undrained Compressive Strength of Cohesive Soils in Tri-axial Compression.
 8. ASTM D 2435 – One-Dimensional Consolidation Properties of Soils.

9. ASTM D 698 – Laboratory Compaction Characteristics of Soil Using Standard Effort.
10. ASTM C 1883 – CBR (California Bearing Ratio) of Laboratory-Compacted Soils.

7.7.0 SURVEY REQUIREMENTS

- A. Within the public domain, the locations and elevations of boreholes and piezometers shall be determined by surveying. Elevation and coordinates shall be shown on boring logs. Station and offset shall be shown on boring logs for street projects and utility line work.

7.8.0 SITE RESTORATION

- A. Site Cleanup along developed right-of-way. Clean the boring site by removing cuttings and mud and other debris. Fill ruts or pits in the ground to original conditions and elevation.
- B. Abandonment of Boring and Piezometers.
 1. Piezometer abandon in accordance with TCEQ Rules, Chapter 238- Well Drillers and Water Well Pump Installers.
 2. Borehole: Backfill with cement grout using tremie method. For non-paved areas and depths less than or equal to ten feet (10'), soil backfill tamped into the borehole is acceptable provided that the conditions and methods are in agreement with TCEQ Rules. Boreholes or piezometers installed in know contaminated areas, or in which contamination otherwise has been detected, shall be abandoned in accordance with the applicable provisions of TCEQ Rules, Chapter 238-Well Drillers and Water Well Pump Installers.
- C. Restoration of Cores Through Pavement. Boreholes or other cored penetrations of pavements shall be restored with the same or equivalent materials as the existing pavement. Do not restore the pavement until the borehole grout has taken initial set to allow for any settlement or shrinkage of the grout.

7.9.0 GEOTECHNICAL REPORT

A sample Table of contents for a typical geotechnical report follows:

Summary:

Field Investigation and Laboratory Testing

1. Introduction
2. Field Investigation
3. Laboratory Testing

Interpretive Report

4. Site Characterization
5. Design Criteria and Recommendations
6. Ground Faults
7. Construction Considerations
8. Monitoring
9. Earthwork Specification and Recommendations

Attachments

- A. Geotechnical report for trench safety system shall be provided for all City of Live Oak projects with excavation over five feet (5') deep. Report shall satisfy statutory requirements for contacting for trench safety construction.

END OF CHAPTER

Chapter 8

STANDARD DRAWINGS

STANDARD DRAWINGS

TABLE OF CONTENTS

Drawing No.	Description	Page
8.1	EXISTING ROAD	76
8.2	EXISTING ROADWAY WITH FLEXIBLE BASE	77
8.3	EXISTING ROADWAY WITH FLEXIBLE BASE SAW CUT PROCEDURE	78
8.4	TRENCH REPAIR IN EXISTING FLEXIBLE PAVEMENTS	79
8.5	TRENCH REPAIR IN EXISTING PCC PAVEMENTS WITHOUT REINFORCING STEEL	80
8.6	TRENCH REPAIR IN EXISTING PCC PAVEMENTS WITH REINFORCING STEEL	81
8.7	NARROW TRENCH CUT	82
8.8	MANHOLE AND VALVE ADJUSTMENT	83
8.9	BRICK SURFACE STREET and BRICK RESTRAINER DETAILS	84
8.10	STREETS TO BE RECONSTRUCTED ADJUSTMENTS FOR CAPITAL IMPROVEMENT PROJECTS	85
8.11	MONITORING WELLS	86

TOP VIEW
EXISTING ROAD

STANDARD DRAWING NO. 8.1

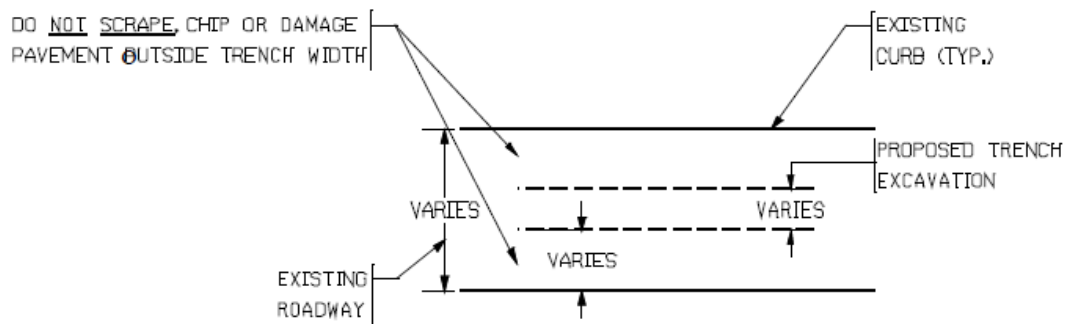

No spoils left on-site for more than 24 hours.

**EXISTING ROADWAY
WITH FLEXIBLE BASE**

STANDARD DRAWING NO. 8.2

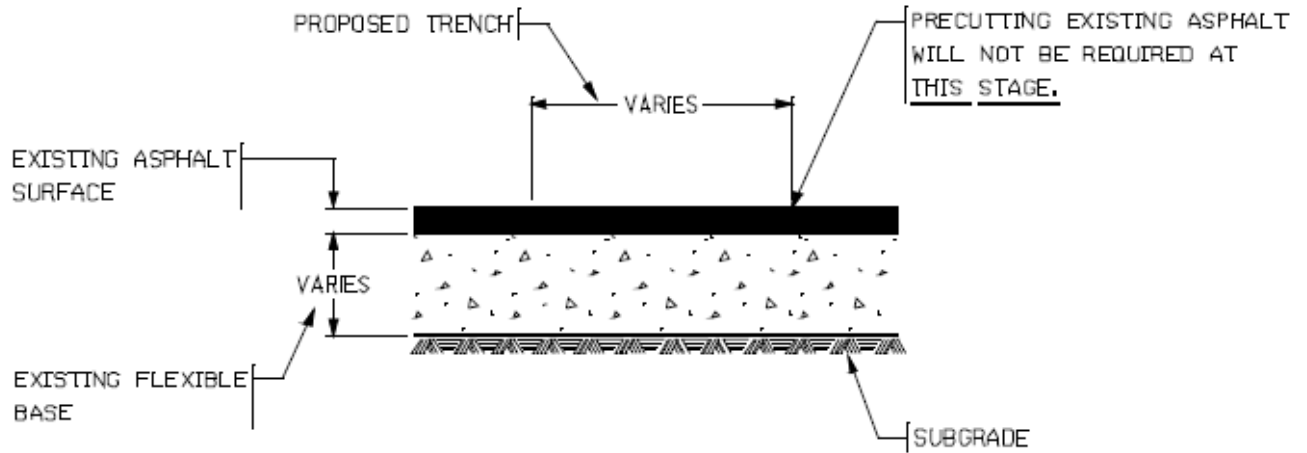

**EXISTING ROADWAY
WITH FLEXIBLE BASE
Saw Cut Procedure**

STANDARD DRAWING NO. 8.3

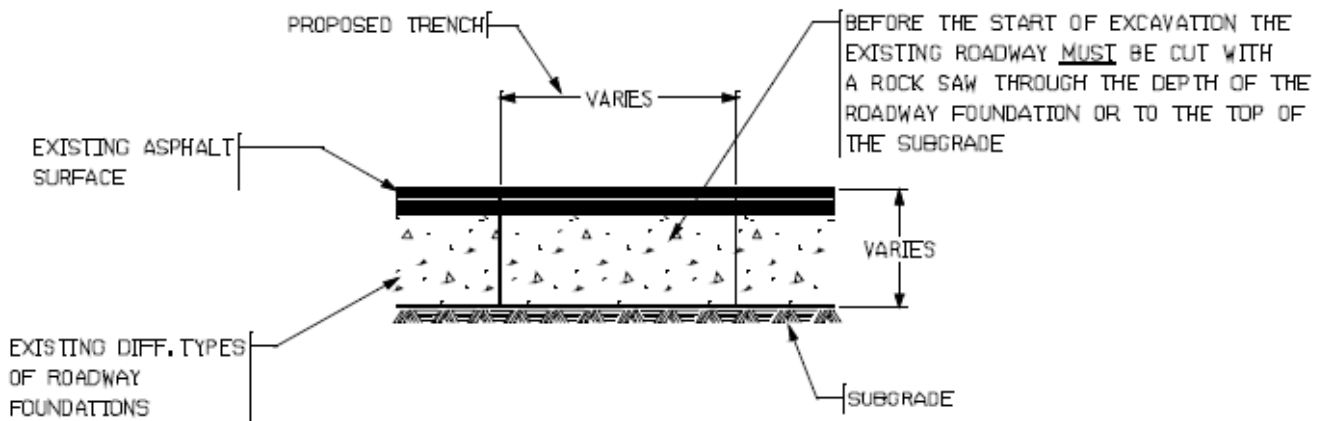

TRENCH REPAIRS IN EXISTING FLEXIBLE PAVEMENTS

STANDARD DRAWING NO. 8.4

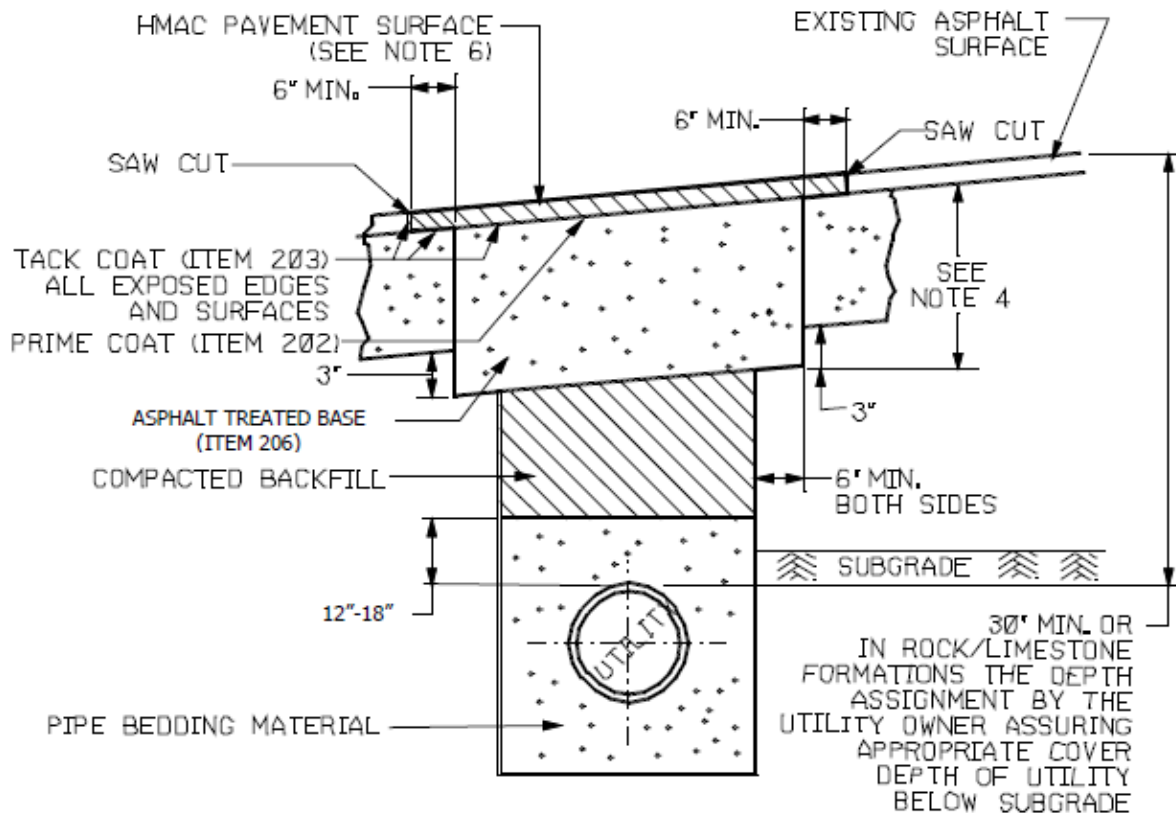

NOTES:

1. THE EXISTING PAVING SURFACE SHALL BE SAW CUT IN A STRAIGHT LINE A MINIMUM OF 12" WIDER THAN UNDISTURBED SIDES OF THE TRENCH SYMMETRICAL ABOUT THE CENTER LINE OF THE EXCAVATION.
2. ANY CONCRETE PAVING SHALL BE SAW CUT 6" WIDER THAN UNDISTURBED SIDES OF EXCAVATION.
3. IF EXCAVATION AREA IS OPEN FOR TEMPORARY PUBLIC USE, THE SURFACE SHALL BE MAINTAINED LEVEL WITH ADJACENT RIDING SURFACE WITH COLD MIX AC OR TEMPORARY HMAC.
4. **LOCAL STREETS SHALL BE 10" AND MAJOR/MINOR STREETS SHALL BE 12".**
5. DAMAGED PAVEMENT OUTSIDE THE TRENCH CUT SHALL BE REMOVED AND REPLACED WITH A BASE THICKNESS OF 10" OR A THICKNESS MATCHING EXISTING, WHICHEVER IS GREATER.
6. REPLACEMENT AC SURFACE LAYER SHALL BE OF THE TYPE AND THICKNESS BASED ON FUNCTIONAL CLASSIFICATION.
 - a) MIN. 2" HMAC TYPE "D" FOR TRENCH REPAIR IN LOCAL/RESIDENTIAL STREETS.
 - b) MIN. 3" HMAC TYPE "C" MODIFIED FOR TRENCH REPAIR IN COLLECTOR/ARTERIAL STREETS.
 SEE ITEM 340, SECTION 340.3 (2).
7. CLASS "J" PCC CONCRETE (ITEM 403) OR CONTROLLED LOW STRENGTH MATERIAL (CLSM) MAY BE SUBSTITUTED IN THESE REPAIRS FOR THE FLEXIBLE BASE AND COMPACTED BACKFILL. PCC CONCRETE GREATER THAN A 2 SACK MIX WILL NOT BE ALLOWED.

**TRENCH REPAIRS IN EXISTING PCC
PAVEMENTS WITHOUT REINFORCING STEEL**

STANDARD DRAWING NO. 8.5

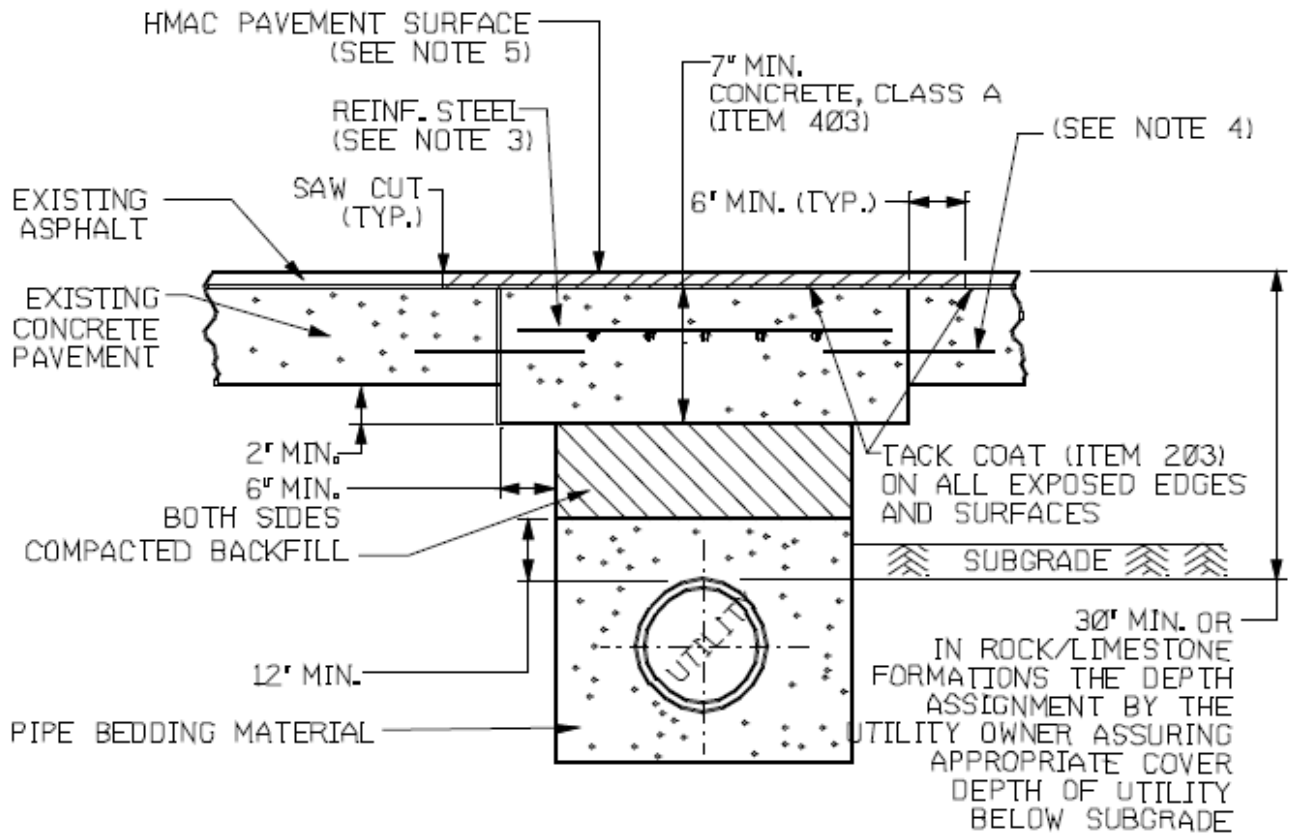

NOTES:

1. EXISTING PC NONREINFORCED CONCRETE SHALL BE SAW CUT TO A MINIMUM DEPTH OF 1½" AT A MINIMUM DISTANCE OF 6" BACK OF THE VERTICAL WALL OF THE UTILITY TRENCH.
2. REPLACEMENT CONCRETE SHALL BE CLASS A AND SHALL MATCH EXISTING FINISH AND THICKNESS, BUT THE THICKNESS SHALL NOT BE LESS THAN 7".
3. REINFORCING STEEL IN THE REPLACEMENT SLAB SHALL BE AT LEAST NO. 4 BARS. REINFORCING STEEL SHALL BE LAP SPLICED ACCORDING TO ITEM NO. 406. IF LENGTH OF LAP CAN NOT BE ACHIEVED, BARS SHALL BE WELDED A MINIMUM LENGTH OF 6"
4. NO. 4 DOWELS SHALL BE INSTALLED AT 12" ON CENTER FOR EXISTING PAVEMENT THICKNESSES 6" OR GREATER.
5. REPLACEMENT AC SURFACE LAYER SHALL BE OF THE TYPE AND THICKNESS BASED ON FUNCTIONAL CLASSIFICATION.
 - a) MIN. 2" HMAL TYPE "D" FOR TRENCH REPAIR IN LOCAL/RESIDENTIAL STREETS.
 - b) MIN. 3" HMAL TYPE "C" MODIFIED FOR TRENCH REPAIR IN COLLECTOR/ARTERIAL STREETS.
- SEE ITEM 340, SECTION 340.3 (2).
6. CLASS "J" PCC CONCRETE (ITEM 403) OR CONTROLLED LOW STRENGTH MATERIAL (CLSM) MAY BE SUBSTITUTED IN THESE REPAIRS FOR THE FLEXIBLE BASE AND COMPACTED BACKFILL. PCC CONCRETE GREATER THAN A 2 SACK MIX WILL NOT BE ALLOWED.

**TRENCH REPAIRS IN EXISTING PCC
PAVEMENTS WITH REINFORCED STEEL**

STANDARD DRAWING NO. 8.6

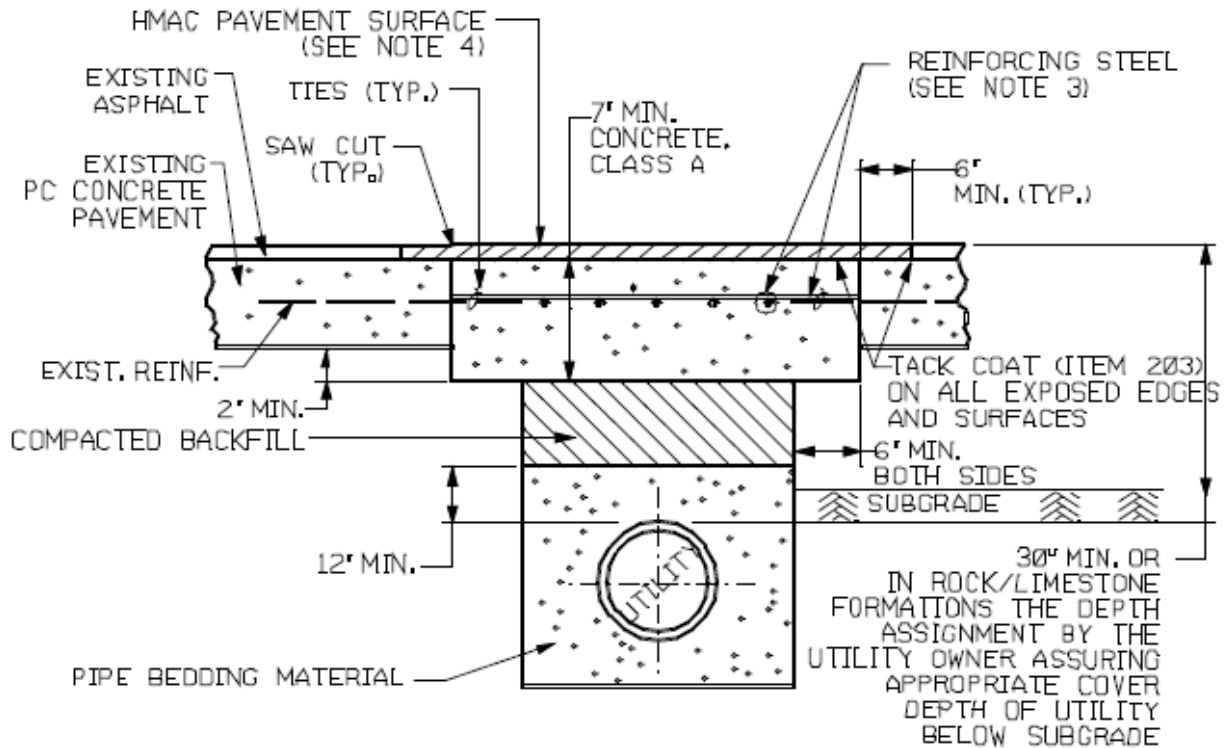

NOTES:

1. EXISTING REINFORCED CONCRETE SHALL BE SAW CUT TO A MINIMUM DEPTH OF 1 1/2' AT A MINIMUM DISTANCE OF 6' BACK OF THE VERTICAL WALL OF THE UTILITY TRENCH.
 2. REPLACEMENT REINFORCED CONCRETE SHALL BE CLASS A AND SHALL MATCH EXISTING FINISH AND THICKNESS, BUT THE THICKNESS SHALL NOT BE LESS THAN 7'.
 3. REINFORCING STEEL IN THE REPLACEMENT SLAB SHALL BE AT LEAST NO. 4 BARS. REINFORCING STEEL SHALL BE LAP SPLICED ACCORDING TO ITEM NO. 406. IF LENGTH OF LAP CAN NOT BE ACHIEVED, BARS SHALL BE WELDED A MINIMUM LENGTH OF 6'.
 4. REPLACEMENT AC SURFACE LAYER SHALL BE OF THE TYPE AND THICKNESS BASED ON FUNCTIONAL CLASSIFICATION.
 - a) MIN. 2" HMAC TYPE "D" FOR TRENCH REPAIR IN LOCAL/RESIDENTIAL STREETS.
 - b) MIN. 3" HMAC TYPE "C" MODIFIED FOR TRENCH REPAIR IN COLLECTOR/ARTERIAL STREETS.
- SEE ITEM 340, SECTION 340.3 (2).
5. CLASS "J" PCC CONCRETE (ITEM 403) OR CONTROLLED LOW STRENGTH MATERIAL (CLSM) MAY BE SUBSTITUTED IN THESE REPAIRS FOR THE FLEXIBLE BASE AND COMPACTED BACKFILL. PCC CONCRETE GREATER THAN A 2 SACK MIX WILL NOT BE ALLOWED.

NARROW TRENCH CUT

STANDARD DRAWING NO. 8.7

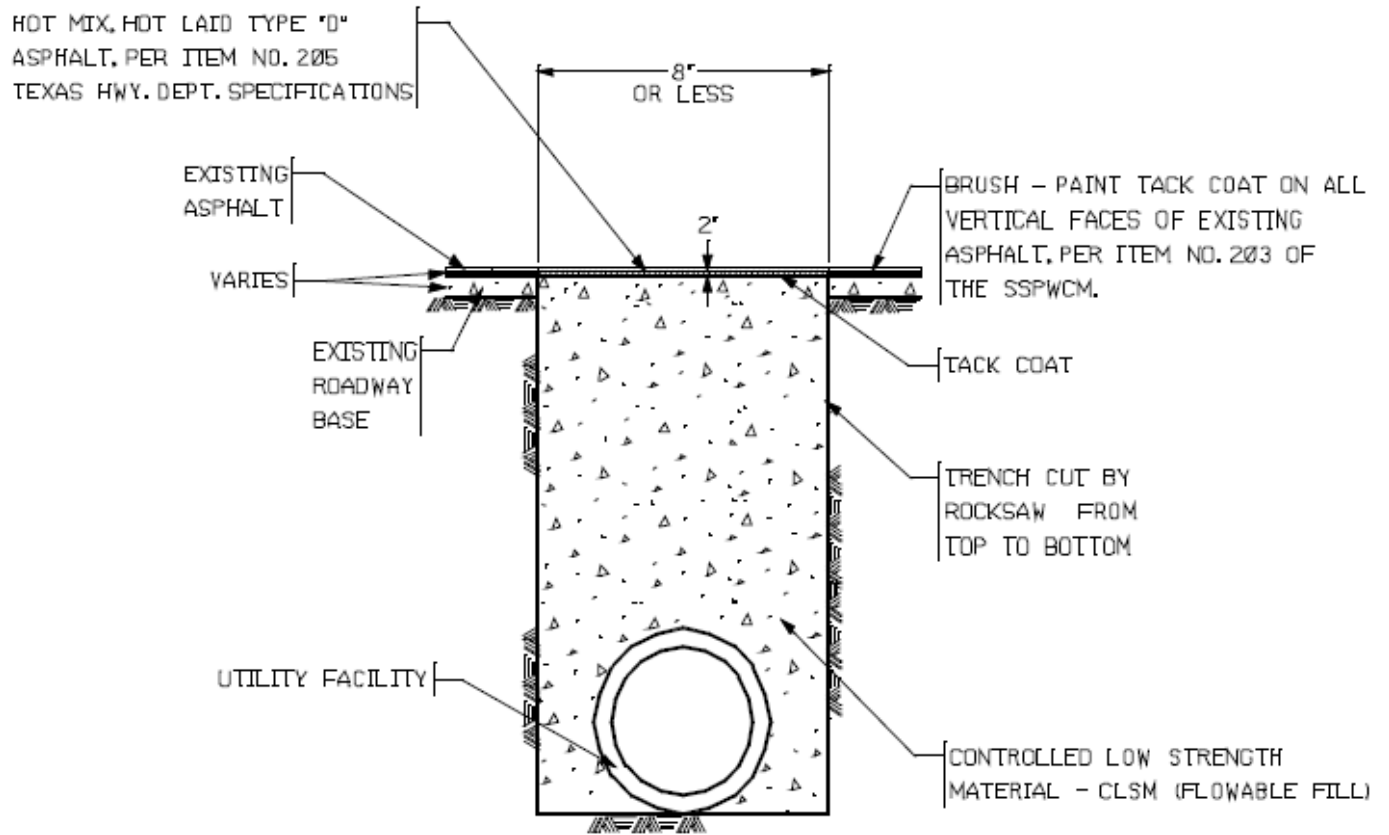

MANHOLE AND VALVE ADJUSTMENT

STANDARD DRAWING NO. 8.8

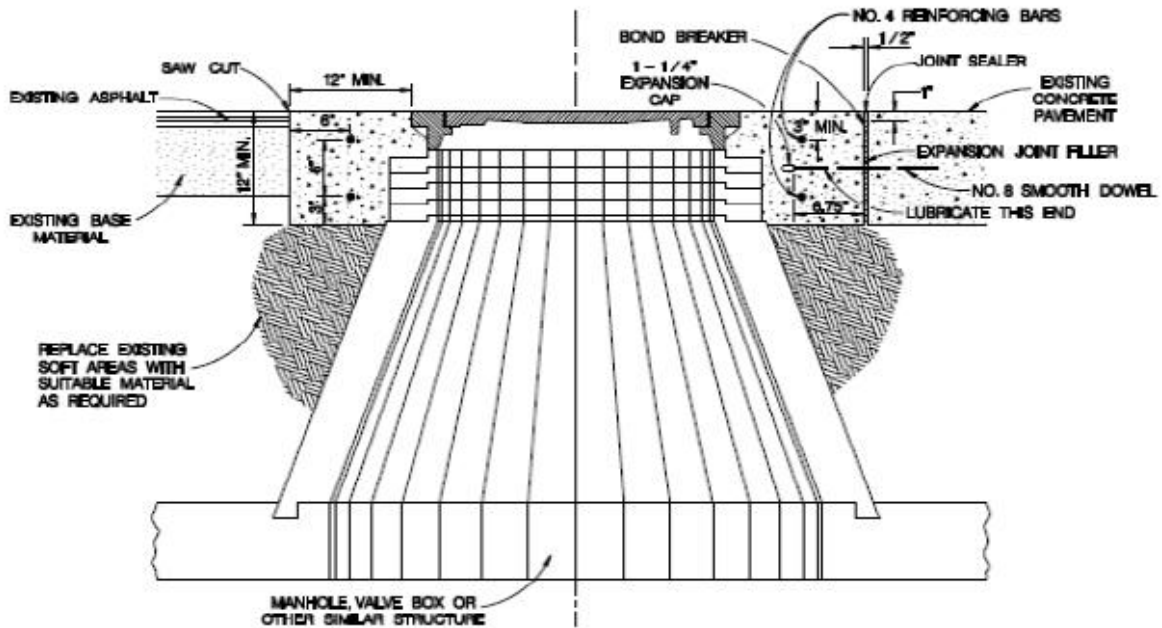

SECTION A-A
NOT TO SCALE

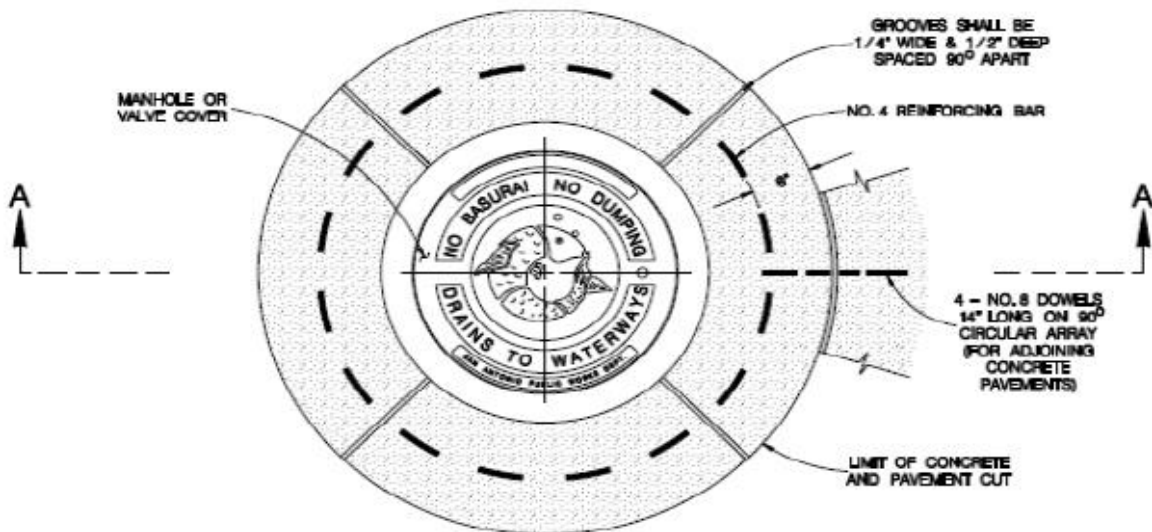

NOTE:

1. THE CONCRETE SHALL BE 4000 PSI, MIN., AND REINFORCED WITH NO. 4 BARS AS SHOWN.
2. THE CONCRETE SHALL EXTEND TO EDGE OF SAW CUT PAVEMENT EDGE.

MANHOLE AND VALVE CONCRETE ENCASEMENT

NOT TO SCALE

AUGUST 2011

NOTE:

THE CONCRETE SHALL BE 3000 PSI, MIN., AND REINFORCED WITH NO. 4 BARS, AS SHOWN.
THE CONCRETE SHALL EXTEND TO EDGE OF SAW CUT PAVEMENT EDGE.

BRICK SURFACE STREET DETAIL

STANDARD DRAWING NO. 8.9

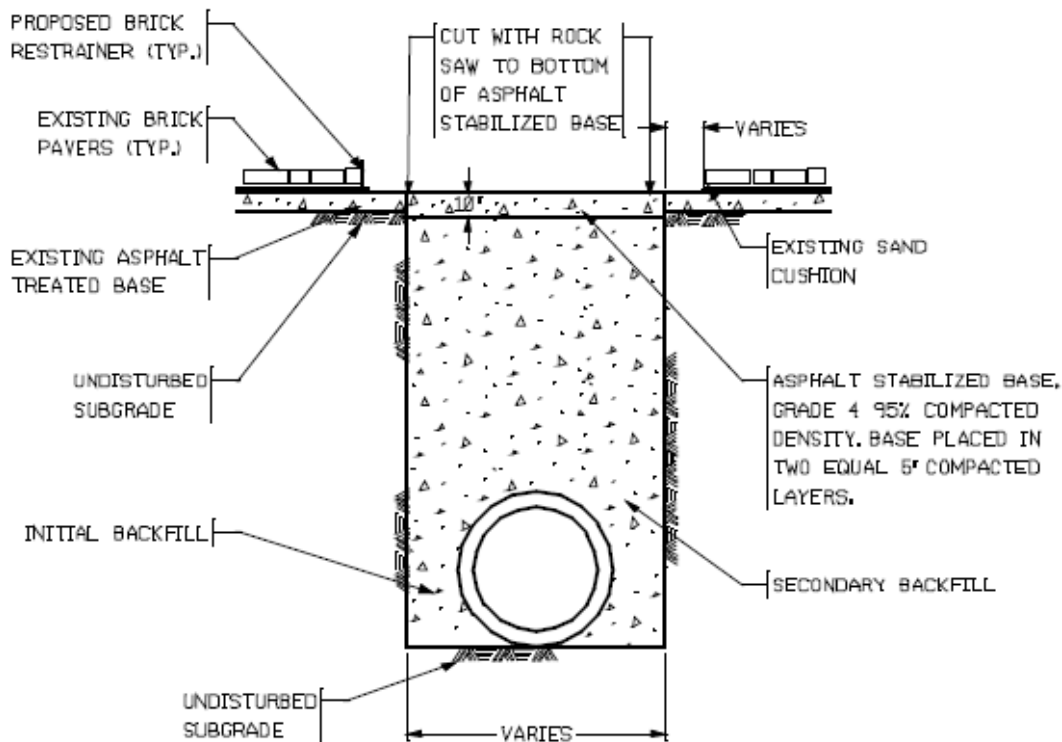

BRICK RESTRAINER DETAIL

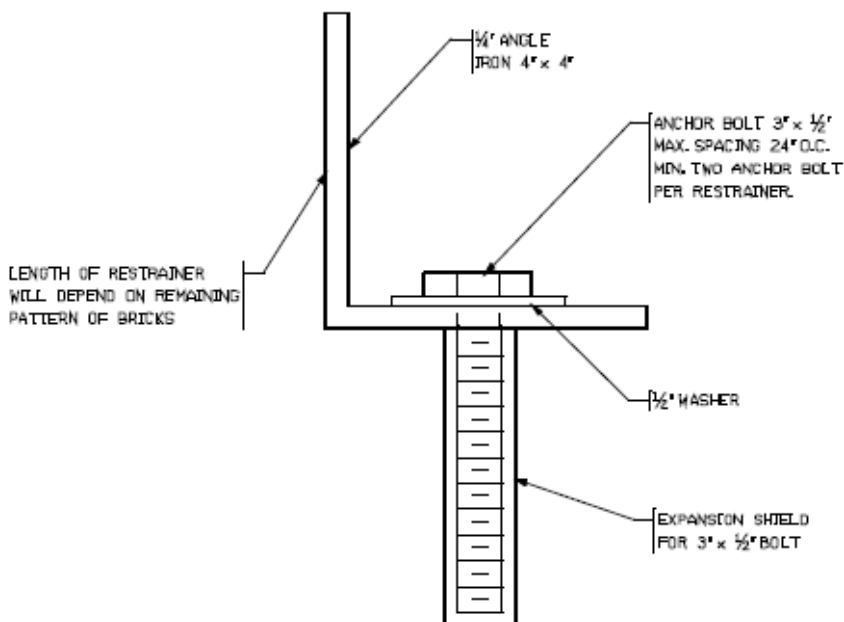

STREETS TO BE RECONSTRUCTED
ADJUSTMENTS FOR CAPITAL IMPROVEMENT PROJECTS

STANDARD DRAWING NO. 8.10

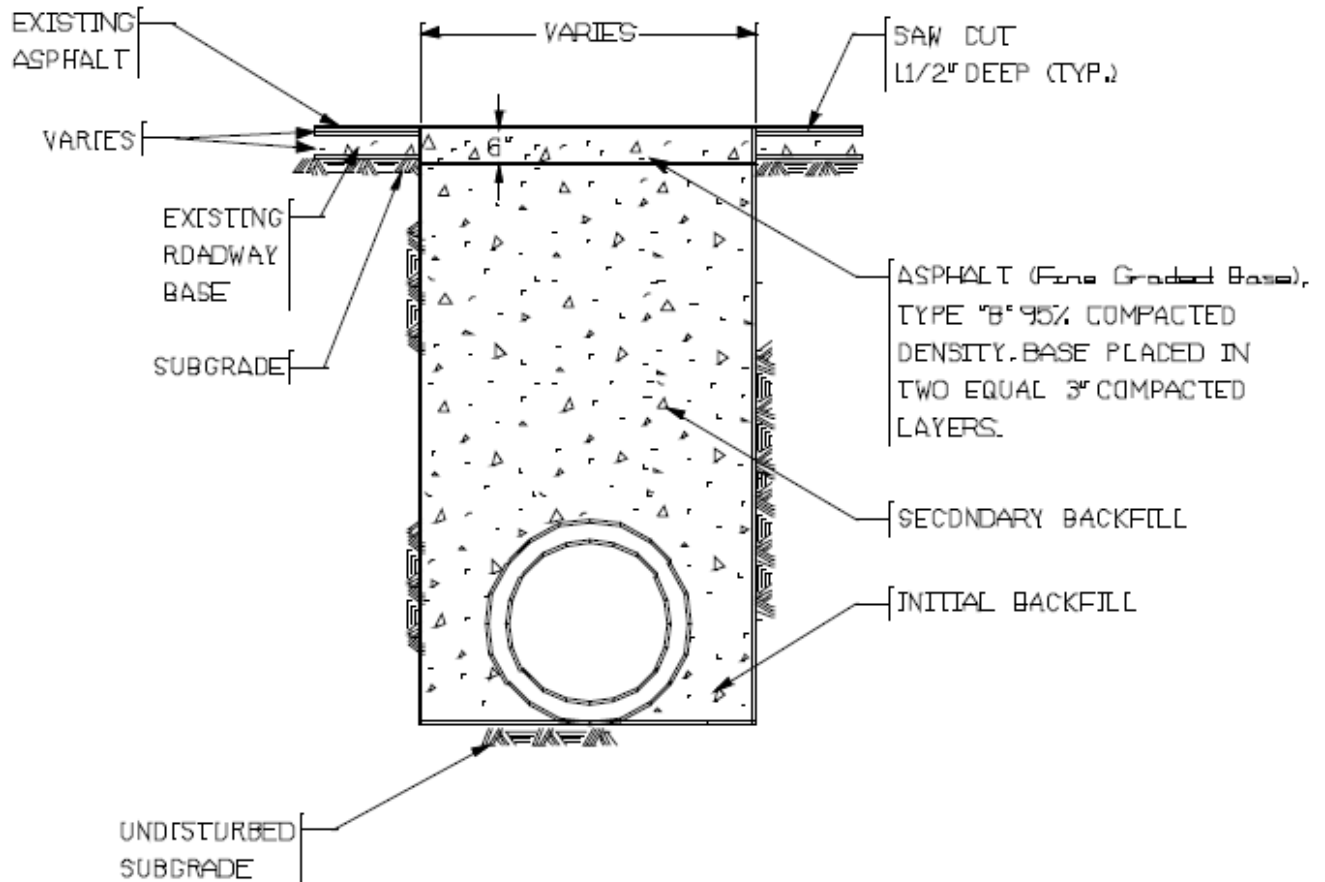

MONITOR WELL DETAIL

STANDARD DRAWING 8.11

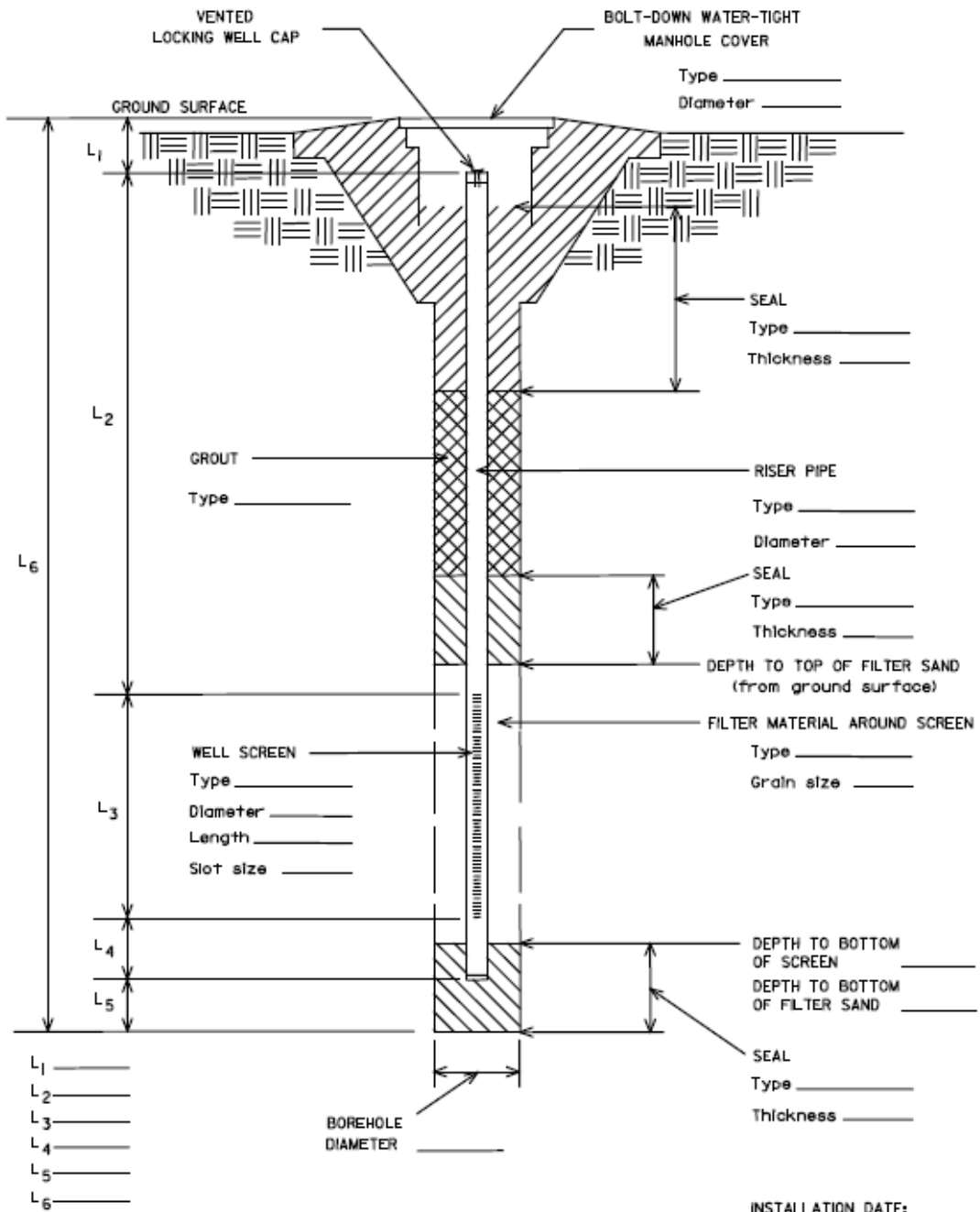

DRILLING CONTRACTOR(S) NAMEs _____

INSTALLATION DATE: DATE _____ TIME _____